

MICHIGAN STATE
UNIVERSITY

MICHIGAN STATE UNIVERSITY *Spring 2012*

Design Day

COLLEGE OF ENGINEERING



Executive Partner Sponsor of Design Day

AUTO-OWNERS INSURANCE COMPANY
AUTO-OWNERS LIFE INSURANCE COMPANY
HOME-OWNERS INSURANCE COMPANY
OWNERS INSURANCE COMPANY
PROPERTY-OWNERS INSURANCE COMPANY
SOUTHERN-OWNERS INSURANCE COMPANY



~ Serving Our Policyholders and Agents for More Than 90 Years ~

April 27, 2012

Dear Students, Family Members, Company Representatives, Alumni, Faculty & Staff:

On behalf of Auto-Owners Insurance Company, and in partnership with Michigan State University, it gives us great pleasure to welcome you to the beautiful MSU campus and specifically to the MSU College of Engineering Design Day. We are pleased and honored to partner with Michigan State University in this program, which showcases the talents and abilities of many gifted students.

It has been said the future belongs to the youth. If this is the case, (which we believe to be true) by the creativity, imagination, and initiative displayed by the participating students in this year's Design Day Program, you have to admit the future looks very bright indeed. A tremendous array of skills and abilities will be displayed this year, which further substantiates our continued support of this program. We congratulate each participant along with those who have provided support, guidance and instruction to them.

As a recruiter of talent for the ongoing needs of our Company, we could not be more pleased with programs like Design Day, or the constant exposure to creative thinking that is provided through the daily course work at Michigan State University. We hire many graduates from numerous disciplines at MSU, and find them to be dedicated, hard working individuals who quickly become solid members of our team. We could not be more proud. Auto-Owners Insurance has called Michigan home since our beginning in 1916. We consider ourselves, along with Michigan State University, one of the great success stories in this state. Last fall we were ranked "Highest in Customer Satisfaction with the Auto Insurance Claims Experience, Four Years in a Row" by J.D. Power and Associates. One of the reasons we are able to receive such a great recognition and continue to grow is because of our outstanding associates and our partnership with great local agencies.

We wish you a truly pleasant, exciting and stimulating day here on the MSU campus. May you be thrilled by the talent of the participants as well as the deep heritage of this campus. We at Auto-Owners Insurance join in congratulating all the participants, proud parents, and sponsors who took the initiative to support this program. Our best wishes to all for a wonderful day!

Jeffrey F. Harrold, CPCU, CLU, ChFC
Chairman & CEO



"Highest in Customer Satisfaction with the Auto Insurance Claims Experience"

-- J.D. Power and Associates



Auto-Owners Insurance ranks highest in the proprietary J.D. Power and Associates 2011 Auto Claims StudySM. Study based on 11,811 total responses, ranking 26 insurance providers. Excludes those with claims only for glass/windshield, theft/stolen, roadside assistance or bodily injury claims. Proprietary results based on experiences and perceptions of consumers surveyed March-July 2011. Your experiences may vary. Visit jdpower.com.

Program Page/Course Number

Table of Contents: April 27, 2012

<i>A Note from the Design Day Director, Maureen E. Blazer-Adams</i>	3
<i>Union Building Floor Plan</i>	4
<i>Design Day Events Schedule, Friday 27 April, 2012</i>	5
<i>Staff Acknowledgements: College of Engineering Design Day</i>	6
<i>The Dart Foundation Day for 7th-12th Grade Students: April 29, 2011: Middle School & High School Events Schedule</i>	7-9
<i>EGR 100: Introduction to Engineering Design: Problem Statement</i>	10
<i>AES Applied Engineering Sciences Capstone Projects: Presentation Schedule–Gold Rooms A & B</i>	11
<i>AES Capstone Project Sponsors and Award Sponsor List</i>	12
<i>Bath Charter Township: Establishing a Database of Artisans and Small Farmers and Recommendations for Leveraging the Current Farmers' Market</i>	13
<i>Composite Materials and Structure Center: A Marketing Study for Applications of a Process to Improve Adhesion Using UV Light</i> . 14	
<i>MSU Surplus Store: Recommendations for a Process to Recycle Glass on the MSU Campus</i>	15
<i>MSU Surplus Store: Recommendations for Improved Marketing and Operations for Student Storage Services</i>	16
<i>MSU Office of Campus Sustainability: Recommendations for Conserving Drinking Water in Academic Units</i>	17
<i>MSU Office of Campus Sustainability: Recommendations for Conserving Drinking Water in Residence Halls</i>	18
<i>Starting Now LLC: Recommendations for Measuring Sustainability Tools to Capture Client Needs</i>	19
<i>XG Sciences: A Marketing Study for Applications of Graphene Paper</i>	20
<i>Peckham Industries: Development of a More Accurate Costing Analysis of Job Floor Processes</i>	21
<i>Peckham Industries: Recommendations for Quality Improvement of the “Foliage Green Thermopro Jacket”</i>	22
<i>BE 485/487: Biosystems Engineering Capstone Projects</i>	23-30
<i>CE 495 Design Engineering Project: Capstone Projects in Civil Engineering MSU and Lake Michigan Rooms</i>	32-33
<i>ChE 434: Process Design & Optimization II Capstone Projects</i>	34-35
<i>MSE 466: Capstone in Materials Science and Engineering</i>	36-37
<i>Computer Science and Engineering: Capstone Course Sponsors</i>	38
<i>CSE 498 Computer Science & Engineering Capstone Projects: Presentation Schedule–Lake Ontario Room</i>	39
<i>Auto-Owners Insurance Company: Enterprise Learning Management System</i>	40
<i>The Boeing Company: Design, Fly and Compete Flight Simulator</i>	41
<i>The Dow Chemical Company: Global Water Dashboard</i>	42
<i>GE Aviation: Mobile Avionics Weather</i>	43
<i>Meijer: Food Safety Audits and Reports</i>	44
<i>Motorola Mobility: Context-Driven Content Delivery</i>	45
<i>Mozilla Corporation: In-Content Preferences for Firefox</i>	46
<i>Plex Systems: HTML5-Based WYSIWYG Label Designer</i>	47
<i>Raytheon: Android VoIP Communications System</i>	48
<i>Spectrum Health Systems: Web Applications for Healthier Communities</i>	49
<i>TechSmith: Mobile Smart Video Player</i>	50
<i>Urban Science: Infographics Generator</i>	51
<i>Computer Science and Engineering: Design Day Awards Fall 2011</i>	52-53

Program Page/Course Number

Table of Contents: April 27, 2012

<i>ECE 101 ECE Robot Competition: Freshman/Sophomore Electrical and Computer Engineering Robot Competition.....</i>	55
<i>ECE 410 VLSI Design Course Introduction: Design and Characterization of a CMOS 8-Bit Microprocessor Data Path.....</i>	56
<i>ECE 480 Electrical and Computer Engineering Capstone Projects: Presentation Schedule–Lake Huron Room.....</i>	57
<i>MSU and Dow Chemical: Tanzania Humanitarian Project: GSM Data Link for Satellite Control.....</i>	58
<i>Texas Instruments: Wireless Sensing System for Intelligent Concrete Curing.....</i>	59
<i>Air Force Research Laboratory: Android Enabled Programmable Camera Positioning System.....</i>	60
<i>Air Force Research Laboratory: A Minimal Size, Weight, and Power System for Key Length Value Metadata Generation for Remotely Piloted Vehicle Sensors.....</i>	61
<i>Lincoln Laboratory: Interactive Radar Demonstration for Children.....</i>	62
<i>Robotic Hyena Project: Animatronic Hyena for Field Research in Kenya.....</i>	63
<i>XG Sciences: Battery Cell Testing Chamber, an Accurate Control System.....</i>	64
<i>Battelle: Remote Control and Monitoring of Sensors by Android Smartphone.....</i>	65
<i>ArcelorMittal: Blast Furnace Moisture Measurement Device.....</i>	66
<i>Design Day Awards: Electrical and Computer Engineering Awards.....</i>	68-69
<i>ME Projects: Mechanical Engineering Design Program.....</i>	72
<i>Design Day Awards: Mechanical Engineering Awards.....</i>	73-74
<i>ME 371: Mechanical Design I: Thrills for Pre-Collegiates: Mechanisms that Fascinate, Captivate, Stimulate and Entice.....</i>	75
<i>ME 412: Heat Transfer Laboratory: The Hot Wort Chiller.....</i>	76
<i>ME 471: Mechanical Design II: Radioactive Waste Container Removal Device.....</i>	77
<i>ME 478: Product Development: Amphibious Vehicle Design.....</i>	78
<i>ME 481 Mechanical Engineering Capstone Projects: Presentation Schedule–Lake Superior and Tower Rooms.....</i>	80
<i>American Hydromech: Solid Particle Contaminant Test Stand.....</i>	81
<i>Robert Bosch, LLC: Fuel Return Line Service Tool for Diesel Piezoelectric Injector Systems.....</i>	82
<i>Chrysler LLC: Front Seat Adjustable Armrest.....</i>	83
<i>Ford Motor Company: Direct Connection of Fuel Vapor Hose.....</i>	84
<i>Louis Padnos Iron & Metal Company: Inductive Proximity Sensor.....</i>	85
<i>Whirlpool Corporation: Adjustable Ice Level Control for an Ice Maker.....</i>	86
<i>Whirlpool Corporation: Solar Powered Refrigerator.....</i>	87
<i>Whirlpool Corporation: Variable Temperature Water Dispensing System.....</i>	88
<i>Nexteer Automotive: Optimization of Torsion-Bar Component Design.....</i>	89
<i>Rennco LLC: Lift Seal-Pouch Seal Validation.....</i>	90
<i>A Shell Oil Company Humanitarian Project: The Appropriate Technology Collaborative: Solar Coffee Dryer.....</i>	91
<i>A Shell Oil Company Humanitarian Project: Heartwood School: Interactive Garden Additions.....</i>	92
<i>A Shell Oil Company Humanitarian Project: Heartwood School: MOVE Delivery Cart.....</i>	93
<i>A Shell Oil Company Humanitarian Project: Lansing Schools K-8 STEM Academy: Year-Round Vermicomposting Bin.....</i>	94
<i>Peckham: Recyclable Fabric Defect Marking Methods.....</i>	95
<i>ME 491 International Development Projects.....</i>	97-102



A note from the Design Day Director

The College of Engineering welcomes you to Design Day! We wish you a very memorable event as you experience our students and their amazing talents through presentations, competitions, and posters.

For the sixth consecutive semester we are honored to have Auto-Owners Insurance as our Design Day Executive Partner. We want to thank them for their extreme generosity and ongoing commitment to MSU's engineering students. A Lansing based Fortune 500 company; Auto-Owners Insurance has a rich history of engagement with Michigan State University, the College of Engineering and Design Day.

As you visit our various exhibits throughout the MSU Union, please take time to learn about the projects. Our students are an incredible group of people who love to share their enthusiasm for engineering.

An exciting part of Design Day is the approximately 200 high school students participating in the Dart Foundation Day of Engineering Innovation and Creativity for 7th-12th Grade Students. These future engineers will explore design principles with hands-on projects requiring the application of their creativity and ingenuity.

The headliners of the day are our graduating seniors as they present their design projects through exhibits, posters, and presentations. These projects represent the capstone of their educational career. You will see that MSU engineers are ready to lead, create, and innovate.

Design Day would not be possible without the continued support of our project sponsors who provide both funding and a professional experience for our capstone design teams.

We appreciate all of their generosity and time.

Along with our Executive Partner, Auto-Owners Insurance, we thank our Directing Partner, GE, and our Supporting Partners, Dow Chemical Corporation, Michigan State University Federal Credit Union, and Norfolk Southern.

Please join us for the Design Day Awards ceremony in the Ballroom at 1:15 pm when we will honor all of our talented Spartans, the best of the best.

Sincerely,

A handwritten signature in black ink that reads "Maureen E. Blazer-Adams". The signature is written in a cursive, flowing style.

Maureen E. Blazer-Adams
Director, Design Day
MSU College of Engineering

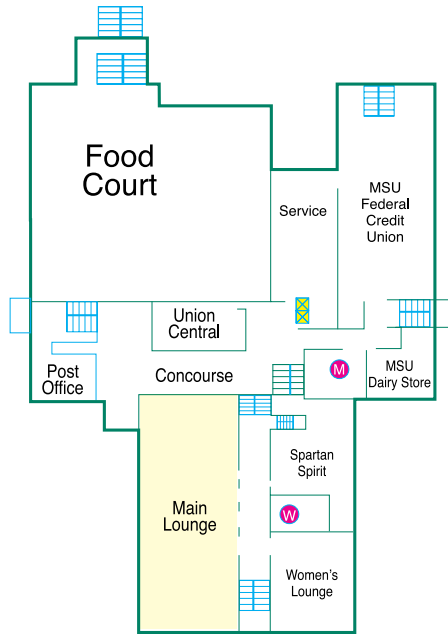

First Floor

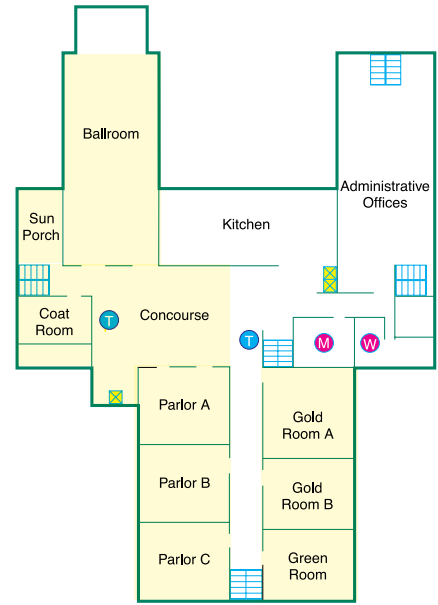

Second Floor

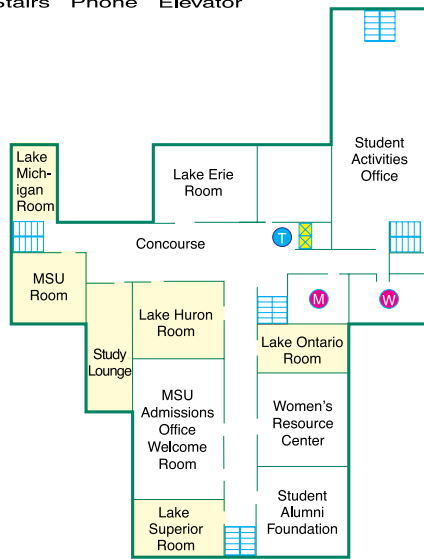
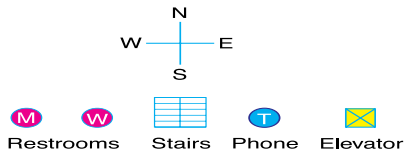

Third Floor

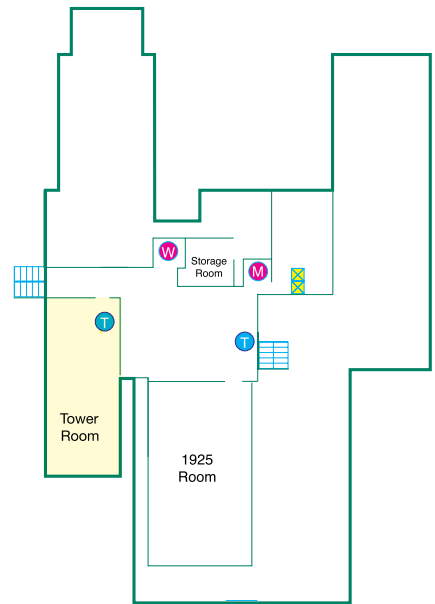







Fourth Floor

MSU Union Floor Plan

Design Day Events Schedule: Friday, April 27, 2012

EVENTS	8 a.m.	9 a.m.	10 a.m.	11 a.m.	Noon	1 p.m.
Audio Enthusiasts and Engineers	2nd Floor Concourse 8:00 a.m. – 1:00 p.m.					
Engineering Student Organizations		2nd Floor Concourse 9:00 a.m. – Noon				
ECE 101 Introduction to Electrical and Computer Engineering	11:00 a.m.	2nd Floor Concourse 9:30 – Noon				
EGR 100 Presentations		Ballroom 9:00 a.m. – Noon				
ECE 410 Design Project Posters		2nd Floor Concourse 10:00 a.m. - Noon				
ME 371 Demonstrations		Ballroom 9:00 a.m. - Noon				
ME 412 Competition		Parlor A 8:20 a.m. - Noon				
ME 471 Competitions		Ballroom 9:00 a.m. - 11:20 a.m.				
ME 478 Competitions		South Porch 9:00 a.m. - 11:20 a.m.				
Posters for ME 491	2nd Floor Concourse 8:00 a.m. - Noon					
CAPSTONE COURSES						
Capstone Posters for most projects, including BE 485/487, ChE 434 and MSE 466	1st Floor Lounge 8:00 a.m. - Noon					
AES 410 Project Presentations	2nd Floor Gold Room A and Gold Room B 8:00 a.m. - 11:40 a.m.					
CE 495 Project Presentations	Lake Michigan Room 8:00 a.m. - Noon					
CE 495 Project Presentations	MSU Room 8:00 a.m. - Noon					
CSE 498 Project Presentations	Lake Ontario Room 7:30a.m. - 11:45 a.m.					
ECE 480 Project Presentations	Lake Huron Room 8:00 a.m. - Noon					
ME 481 Project Presentations	Tower Room 8:00 a.m. - Noon					
ME 481 Project Presentations	Lake Superior Room 8:00 a.m. - Noon					
LUNCH AND AWARDS						
MSU Lunch	2nd Floor Concourse 12:15 p.m. - 1:00 p.m.					
MSU Awards	Ballroom 1:15 p.m.- 2:00 p.m.					
School Awards	Parlor C Noon - 12:15 p.m.					
School Lunch	Brody Hall 12:15p.m. - 1 p.m.					

KEY:  AES event  CE event  CSE event  ECE event
 EGR event  ME event  School event

STAFF ACKNOWLEDGEMENTS:



Roy Bailiff



Jill Bielawski



Linda Clifford



Kelly Climer



Cathy Davison



Craig Gunn



Phil Hill



Matt Jennings



Debbie Kruch

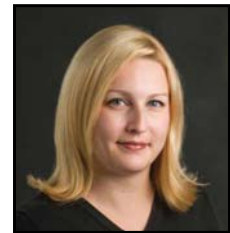

Jamie Lynn Marks



Steve Marquie



Garth
Motschenbacher



Mary Mroz



Gregg Mulder



Roxanne Peacock



Adam Pitcher



Jeanette Robertson



Meredith Schmidt



Norma Teague



Teresa VanderSloot



Brian Wright

MACHINE SHOP AND DESIGN LAB STAFF:

Ken Barlage, Russ Tindall
and Colin Perrault



Dart Day of Innovation and Creativity *for 7th-12th Grade Students*



Our Future Lies in Some Very Precious Hands...

At the Dart Foundation, we are committed to developing scientifically literate students in Michigan. We're proud to sponsor the MSU College of Engineering Design Day for pre-collegiate students.

Funded by the Dart Foundation



MICHIGAN STATE UNIVERSITY | College of Engineering

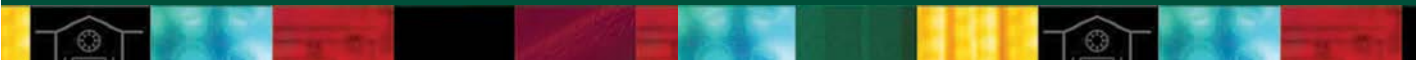

The Dart Foundation Day for 7th-12th Grade Students

April 27, 2012

Precollege Student Voting: *During the morning on Design Day all visiting precollege students will be viewing and voting on Engineering Projects throughout the morning of Design Day.*

During this time, college students will have a chance to interact with “non-engineering” students and demonstrate the underlying principles from their projects. This interaction allows the college students an opportunity to practice explaining engineering concepts to non-engineers. As the precollege students work their way through the wide variety of presentations, they will get an overview of the many different branches of engineering. Additionally, as the precollege students see both entry-level and advanced engineering applications, it allows them to see the natural progression of engineering. Lastly, this session also provides a chance for the precollege students to interact with student organizations within the College of Engineering.

	C.E./M.E. Team Build Parlor B – 2nd Floor	VEX Robotics Parlor C – 2nd Floor	1st & 2nd Floor Voting/ project viewing, including Dr. Kwon’s amphibious vehicle
9:00–9:55	Schools 1 & 2	Schools 5 & 6	Schools 3 & 4
10:00–10:55	Schools 3 & 4	Schools 1 & 2	Schools 5 & 6
11:00–11:55	Schools 5 & 6	Schools 3 & 4	Schools 1 & 2
12:00–12:10	All students in Parlor C for the awards ceremony. Lunch at Brody will immediately follow the awards ceremony.		

VEX ROBOTICS

Our team of experts has designed a lab experience to give precollege students an introduction to robots. Students will work in small groups and have a hands-on approach learning to control the VEX robot. They will write programs using Robot C language and they will program the robot to be controlled by a remote control. Application and discovery of how programming works will be similar to lessons presented in science and math classes. Each team will discover how to adjust their programs based upon the program inputs and actual output (robot performance). During each phase, new challenges will be introduced to engage the students. This will reinforce new ideas and concepts while exposing students to the newly emerging capabilities of student-controlled robotics programs.

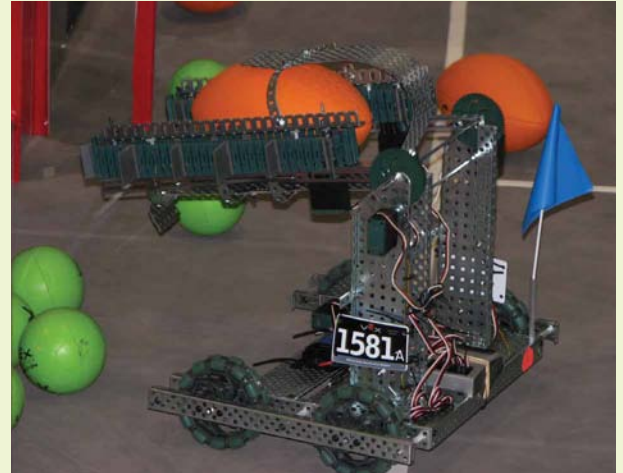

INTERDISCIPLINARY ENGINEERING BUILD

In this build you and your team will be integrating practices from multiple fields of engineering to build and evaluate a support system. Support systems can range from simple beams to intricate bridges composed of gussets, trusses, cables, etc. These types of systems are used throughout Civil, Mechanical and Structural Engineering works. This session will start with a brief introduction to the forces and stresses that act on support systems. Additionally, you will see how digital sensors can read and convey data about these stresses to a computer. We will also look at the computer code that takes this raw data and converts it into a format that can easily be interpreted.

During the build portion of this session you and your team will be given the design constraints for the structure. Utilizing the information learned at the start of the session and the limited materials provided, your team will need to design and then construct a model to be tested. Your finished structure will be placed on one of our test beds for evaluation. With the help of MSU Engineering students, the results will be collected by a sonic ranging sensor. These data points will be interpreted by the computer program and your team will be evaluated on percent deflection of your support. Throughout this session you will need to listen, learn and utilize your team to be successful. Good Luck.



Drew Kim
MSU Engineering
Assistant to the Dean
Recruitment, Scholarships,
and K-12 Outreach



Luis Donadoto
Assistant Director of
MSU Engineering
Recruitment and
K-12 Outreach



Jamie Lynn Marks
MSU Engineering
Recruitment and
K-12 Outreach



Russ Pline
Okemos High School
and MSU Engineering
Recruitment and K-12
Outreach Design Day
Coordinator



Bob Watson
MSU Engineering
K-12 Outreach
LEGO and VEX
Robotics Coordinator

EGR 100

9:00 a.m. – Noon
Second Floor
Ballroom



INTRODUCTION TO ENGINEERING DESIGN

Instructor:
Mr. Timothy Hinds

Project Engineer:
Sandra Christlieb

Marc Santa
Kurt Webb

Jessica Holberg
Nur Azan Joned

RCPD Liaison:
Stephen Blosser

George Wimbrow

Franklin Luchini

Mentor Staff:

Kyle Melzer

TA Staff:

Christina Barry

Ian Neerken

Wouter Brink

Ben Blaut

Alexander Pucci

Lauren Fedak

Scott Crichton

Vanessa Stuart

Eric McElmurry

John Gaiser

Matthew Wiggans

PROBLEM STATEMENT

EGR 100, Introduction to Engineering Design, is a college-level course required of all incoming first-year engineering students. It is an integral part of the Cornerstone Engineering and Residential Experience (CoRe) programs. The course introduces students to the engineering profession and the engineering design process through team-based, interdisciplinary design projects and assignments. Nearly 400 students are enrolled in EGR 100 this semester.

For the final course project, the student teams selected from three project types: (i) solar water heater design, (ii) Lego® Mindstorms® competition and (iii) MSU Resource Center for Persons with Disabilities (RCPD) design. For the first choice, the student teams were to design, build and test a solar water heater that would successfully increase the temperature of a given volume of water in a fixed time. The prototypes were to fit within a specified test fixture containing the water reservoirs and connection ports. The second choice required the students to build and program an autonomous robot that competes simultaneously against other robots to gather high-scoring, colored balls. Points were awarded to teams based upon the values of the balls in the team's goal area at the end of the competition. The third project type had student teams work with RCPD clients to design and build working prototypes to assist them in daily activities. Teams from each of the three project types will display their prototypes at Design Day along with a poster detailing their design concepts. Pre-college students will recognize the most outstanding projects with awards.

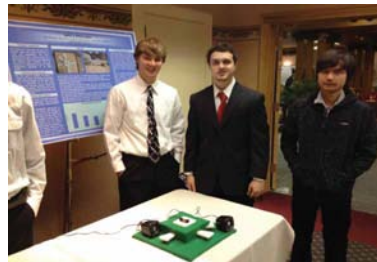

EGR 100 Outstanding Prototype and Poster Award

The EGR 100 Outstanding Poster and Prototype Award recognizes the best project presented by an EGR 100 design team as judged by area middle and high school students.

First Place Fall 2011

Tiger Bourque
Tyler Finses
Tyson Ho
Raji Kiridena
Andrew Schilleman



APPLIED ENGINEERING SCIENCES 2012 CAPSTONE PROJECTS

PRESENTATION SCHEDULE — Gold Rooms A & B

AES 410 Teaching Staff: Dr. Jon Sticklen, Director of AES

Mr. Chris Cheney (right) and Mr. Patrick Kelleher (left)



	Time	Company	Project Title
Local Non-profit	8:00 a.m.	Bath Township	Establishing a Database of Artisans and Small Farmers and Recommendations for Leveraging the Current Farmers' Market (Team 7)
MSU Internal	8:20 a.m.	Composite Materials and Structures Center, College of Engineering	A Marketing Study for Applications of a Process to Improve Adhesion Using UV Light (Team 1)
	8:40 a.m.	MSU Surplus Store	Recommendations for a Process to Recycle Glass on the MSU Campus (Team 3)
	9:00 a.m.	MSU Surplus Store	Recommendations for Improved Marketing and Operations for Student Storage Services (Team 9)
	9:20 a.m.	MSU Office of Sustainability	Recommendations for Conserving Drinking Water in Academic Units (Team 4)
	9:40 a.m.	MSU Office of Sustainability	Recommendations for Conserving Drinking Water in Residence Halls (Team 6)
	10:00 a.m.	Break	
Commercial Companies	10:20 a.m.	Starting Now	Recommendations for Measuring Sustainability Tools to Capture Client Needs (Team 5)
	10:40 a.m.	XG Sciences	A Marketing Study for Applications of Graphene Paper (Team 2)
	11:00 a.m.	Peckham INC	Development of a More Accurate Costing Analysis of Job Floor Processes (Team 8)
	11:20 a.m.	Peckham INC	Recommendations for Quality Improvement of the "Foliage Green Thermopro Jacket" (Team 10)

AES 410 Capstone Course Senior Capstone Project

The AES capstone is the culmination of the entire program. The course covers content new to the students on professional ethics, project management methods, and concepts of six sigma methods. But the strong thrust of the program is the capstone project itself. The capstone project is...

- A project from industry or non-profit companies typically focused at the confluence of modern business operations and engineering or technical issues
- Attacked by a team of 5-6 capstone students
- Is intense, demands substantial time, and - most of all - is a transition for AES seniors from the world of the classroom and the world in which their careers will be built

We gratefully acknowledge
the generous support of the
Eaton Corporation for the
2012 AES Capstone Program.
Thank you, Eaton!



Capstone Project Sponsors and Award Sponsor

We thank the following project sponsors for their generous support of the AES program.

Bath Township



MSU Composite Materials and
Structures Center



MSU Surplus Store



MSU Office of Sustainability



Starting Now



XG Sciences



Peckham Industries



Mr. Phil Fioravante, alumnus of our program, is the 2012 sponsor of awards for AES Capstone projects. Winners are determined based on both final written project reports and on oral presentations at Design Day. We thank Mr. Fioravante for his generous support of the AES program.

Establishing a Database of Artisans and Small Farmers and Recommendations for Leveraging the Current Farmers' Market

First surveyed in 1826 by Harvey Parke, Bath Township has grown from a railroad hub and part of DeWitt Township into its own distinct charter township serving a community of a little over 11,500 residents. Recently, Bath Township has been an integral part of the Southern Clinton County Farm and Food Coalition, whose focus is to “explore opportunities to support healthy food from farm to your plate.” Bath Township officials and residents want their community to remain rural and to decrease the potential for further suburban development. Therefore, Bath Township officials are exploring entrepreneurial business opportunities that will not change the “nature” of their community. However, before the township officials can decide which ventures to pursue they need to understand the capabilities and desires of their residents.

To do so, our group plans to reach out to the Bath community with various surveys for farmers, potential and current patrons, and artisans to form a database of their various local businesses. We will also complete a thorough market analysis, developing in-depth business strategies to improve the Bath community through an enhanced farmer’s market, distribution network, and/or community kitchen.



MSU Team Seven *left to right*

Eric Thomas, Dan Allard, Nuala Christie, Carl Beamish,
Karl Asher, and Patrick Kelleher

A Marketing Study for Applications of a Process to Improve Adhesion Using UV Light

The Composite Materials and Structures Center (CMSC) at Michigan State University in the College of Engineering facilitates the study of polymer composites. The CMSC is internationally recognized for its contributions to composite science and engineering. The center's staff researchers have expertise in processing, design and optimization, materials science, Nano-composite technology, structural analysis, surface science, and failure analysis, along with other studies. The CMSC is internationally recognized for its contributions to composite science and engineering.

Dr. Drzal, director of CMSC, is searching for new applications and markets for a patented process utilizing ultraviolet lights to treat the surface of specific materials to improve adhesion. Some large markets in which this technology could be greatly beneficial are the automotive, aerospace, and sporting goods industries. The UV treatment would replace the current processes that are dominated with other technologies such as flame, corona, plasma and chemical. The CMSC would like to explore these markets further and compete with the existing technologies by delivering a flexible, profitable, sustainable and cost-effective treatment.

This project entails two main objectives: conduct a market analysis of three industries that utilize a competing process, and create a sustainable business plan based around the UV technology that could replace one of the competing processes. Within each of these main objectives there are many other goals involved to complete the objectives. In the end our research and business proposal will be useful for the Composite Materials and Structures Center to help further their advancement in the market.



MSU Team One *left to right*

Jackson Hartman, Josh Frontiera, Tori Mazur, Rachelle Emering,
Ethan Willis, Alex Jones and Dr. Larry Drzal (inset)

Recommendations for a Process to Recycle Glass on the MSU Campus

Our group is taking on the challenge of developing a process to safely and cost-effectively introduce glass recycling to the many campus buildings including academic and athletic buildings and dorms. Our client is the MSU Surplus Store, which is responsible for the disposition of all university surplus properties and provides managed storage services to university departments. The items that they have for sale include office and residence hall furniture, lab equipment and supplies, vehicles, computers, farm equipment, books, and more. The Surplus Store offers storage services as well.

Our main objectives are to gain an understanding of the recycling system currently used at MSU. We will also learn the safety requirements included in the process of glass recycling on campus. We will develop a plan for glass recycling at MSU, in which we will develop an efficient and convenient building collection process. We will also identify collection container options used for glass recycling and develop a logistics plan to ship glass from various buildings to the recycling center in the safest way possible. We plan to develop off-loading procedures for the glass as well. Lastly, we will develop an advertisement plan to inform students about the new glass-recycling program.



MSU Team Three *left to right*

Alonzo Howell, Matthew Epstien, Michael Mitchner,
Kara Bolda, Darian Little, Nicholas Ratliff

Recommendations for Improved Marketing and Operations for Student Storage Services

Sustainability has been a priority at Michigan State University for years. One of the major champions of the effort to “Go Green” on and around campus has been the MSU Surplus Store. In the past, the Surplus Store has managed storage of just about any material for university departments and staff. Over the past three years, the Surplus Store has also begun offering its services to students. Currently, students are able to rent a hamper (a large plastic tote) that the Surplus Store will pick up and deliver to the students’ dorms. Besides hampers, the Surplus Store also uses cardboard boxes for storage of materials. The vision statement of the Surplus Store shares how they hope to become the premier university or college “Surplus Store” through being resourceful, creative, and providing friendly, responsive customer feedback. In alignment with this vision, ideas for offering “green boxes” or plastic boxes for storage have been discussed and looked into. These green boxes would provide a much more sustainable option. Using current logistics and storage facilities, the store manager, Kris Jolley, hopes to improve operations and spread awareness of both the green boxes and the student storage service.

Our goal is to improve and enhance the operations and marketing for the student storage services. With a general framework for student storage in place, we will be focusing on several other important areas. We will be facilitating interdepartmental communication to improve logistics and customer satisfaction. The operations can be improved through cooperation between the Surplus Store, the residence halls, and the student population. By working as advocates for this program around campus, we will be able to improve the overall operations strategy, as well as generate



an effective marketing strategy. This marketing strategy is another major focus of our work. Using both standard campus marketing outlets, as well as social media, we will attempt to popularize the student population with the storage program. Our marketing plan will also include research on local storage alternatives, to make both the pricing and the offerings comprehensive and competitive. The culmination of all these efforts will not only improve the value of the services offered by the MSU Surplus Store, but will improve the overall goal of improved sustainability on and around the MSU campus.



MSU Team Nine
left to right

Vincent Stefano, Aimee Smith, Christine Varley, Patricia Gordon, Daniel Hisscock

Recommendations for Conserving Drinking Water in Academic Units

The MSU Office of Campus Sustainability is the driving force behind Michigan State University's initiative to be Spartan green. A broad scope of ideas and initiatives has driven MSU to be one of the nation's top five most sustainable campuses. Through 15 environmentally centered academic programs, local and worldwide partnerships, cutting edge research, and campus operations that holistically approach waste and greenhouse gas reduction, Spartans are working to create a better world. The goal of the Office of Campus Sustainability and impact of these actions is clean and affordable energy with a more sustainable future for all.

Business Challenge: The business challenge that the MSU Office of Sustainability faces involves personal water consumption campus-wide. Our end goal is to document, analyze, and improve the process of water delivery and consumption while at the same time reducing the level of waste generated. Specific areas of consideration include how reverse osmosis-treated water is used at Sparty's Convenience stores, and how purchasing of five gallon jugs for water coolers is conducted on department and campus-wide levels. Conjectures will be based upon survey data gathered from various locations and departments across campus. Short and long-term recommendations will then be made, with high emphasis placed upon total sustainability.



Objectives:

- To document and generate data on how water is consumed by students at Sparty's locations.
- To analyze purchasing methods and consumption rate of five gallon jugs for water coolers in various departments throughout campus.
- To make sound carbon footprint calculations on present methods and subsequent recommendations.
- To improve overall use of water on campus while generating less waste by using less energy.



MSU Team Four left to right

Ross Crumbaugh, Anthony Iacovoni, Greg Beebe,
Dr. Susan Masten (Sponsor), Brent Haberl, Lance Kohs

Recommendations for Conserving Drinking Water in Residence Halls

Currently the Office of Sustainability at Michigan State University is researching new methods to improve sustainability throughout the campus. The Be Spartan Green initiative leads research, data analysis and collection, programming, outreach, and communications to provide resources and new solutions in order to conserve energy, water, reduce waste, and maintain the campus ecosystem. The topic of conserving water and improving water quality is of great interest to the Office of Sustainability at Michigan State University, as the project will be investigating water consumption by students on campus and how to offer students quality filtered drinking water. The project of interest is guided by the Office of Sustainability's efforts to reduce dependency on bottled water and water cooler water and offer quality drinking water that has a great taste to all Spartans. Our portion of the project will concentrate on water in the residence halls on campus.

Statement of problem definition/deliverables

The current challenge of the project is to focus on why Owen Hall uses more water than all the other residence halls on campus on a per capita basis. The main focus area would be on the residence halls, and the project deliverables include administering a survey to residents with various questions, performing a blind taste test on the drinking water fountains in at least five residence halls to determine which tastes best (either filtered drinking water, bottled water, water from the tap in the building, or East Lansing water used by Brody). The group will be focusing on more operations issues relating to water consumption and usage, including: would it be cost effective to introduce new water filtering facilities at each residence hall, would it make sense to switch more residence halls to East Lansing water, and determining from



where students on campus get their water. Other main objectives of the project include collaborating with the MSU Office of Sustainability to gain an understanding of MSU's entire drinking water system and all drinking water options available to Spartans; gaining an understanding of the filtration process and the quality of the water offered, and recommending a cost-efficient way to provide quality drinking water for all Spartans on campus at all locations.



MSU Team Six *left to right*

Matt McAlpine, Chris Skierski, Dr. Susan Masten (Sponsor),
Alex Voigt, Yifan Chen, Greg Edwards, Anu Sridaran

Recommendations for Measuring Sustainability Tools to Capture Client Needs

Starting Now LLC is a startup consulting service designed to assist organizations, firms, and agencies toward achieving sustainability, one that will benefit the organization, the community and the planet simultaneously. A key metric for the company when taking on new projects is to ensure its clients are committed to taking a 360-degree look at their organization instead of the traditional investor-only approach. Starting Now performs its consulting services by drawing on the extensive experiences of its founder and president, Terry Link. Mr. Link has had many jobs in the industry ranging from Executive Director of the Greater Lansing Food Bank to Director of the Michigan State University Office of Campus Sustainability.

One of Starting Now's current challenges is helping their clients in both calculating and reducing their carbon footprint. Our team is tasked with achieving two things. One, develop an understating of how carbon footprints are measured, and identify relevant tools, particularly tools that are useful to the local restaurant industry. And two, create advertising material that espouses the importance of reducing the largest culprits of carbon footprint by sector.



MSU Team Five *left to right*

Andy Malnor, Ralph Paulk, Terry Link (Sponsor), Avi Kotte,
John Roberts, member Ryan Rivard is not pictured.

A Marketing Study for Applications of Graphene Paper

XG Sciences is a privately held corporation that specializes in, manufactures and sells xGnP® brand graphene nanoplatelets and also develops advanced multifunctional materials based on their nanoplatelets. Graphene Paper had its beginning stages of development at Michigan State University in 2004, and the spinoff company was founded in 2006 from the Michigan State University Composite Center under the direction of Dr. Lawrence Drzal. Today this company is on the leading edge of technology with a material that is not only beginning to create noise in the engineering community but may soon become as popular and more successful than our everyday copper and plastics.

The project summary and objectives include performing market research into applications for graphene paper and providing a recommendation to XG Sciences that will expose a profitable market for this material. Our goal is to provide XG Sciences with information that will link the consumers, customers, and the public to graphene paper and its properties and applications. With this information XG Sciences hopes to expand its tailoring of graphene for specific applications, advanced materials, and energy applications.

To enhance XG Sciences' graphene center, we will perform comprehensive and extensive market research in the field of aerospace corresponding to replacement of copper wiring and enhancing EMI shielding material. XG Sciences will be provided with research on competitors for graphene and in the



aerospace industry, aerospace regulations, economic trends, supply and demand forecasts, market structure and many other factors. Our team will develop a business and action plan in order to implement our market research and strategy.

 **XG sciences**

MSU Team Two
left to right

Genevieve Abisaab, Richard Studstill, Andrew Gretel,
Alex Burgoon, Robert Scipone, Patrick Kelleher, Trevor Harris,
and Dr. Larry Drzal (Sponsor)

Development of a More Accurate Costing Analysis of Job Floor Processes

Peckham, Inc. is a nonprofit organization and one of the largest community vocational rehabilitation organizations in Michigan. The company provides job training and competitive employment opportunities for persons with disabilities. Ever since Peckham's founding in 1976, they have highly valued quality, diversity, and performance. Peckham continuously exceeds the expectations of many with what they have to offer in apparel manufacturing, business services, environmental services, and supply chain solutions. To date, the company's largest customer is the United States Government. The unique business and human services agency has a mission: to provide a wide range of opportunities to maximize human potential for persons striving for independence and self-sufficiency.

Peckham utilizes state-of-the-art apparel software and automated cutting equipment during the apparel spreading, cutting, bundling, and cut part delivery processes. These processes are collectively considered to be the cutting stage of the overall manufacturing process. The cut pieces of material are then ready to proceed to sewing. Currently, the company allocates a flat price to the cutting stage without regard to the garment type, the fabrics each garment calls for, or cut parameters required for each garment and size. Our mission is to develop a should-cost model for the cutting stage on several different types of garments that Peckham manufactures. This will ultimately allow for Peckham to make various managerial decisions about the method used to cost this stage in the manufacturing process.



MSU Team Eight *left to right*

Leah Holoway, Chelsea Wilhelm, Theresa Hampel (Sponsor),
Michael Lask, Andrew Hall, Brian Noble, and Patrick Kelleher (GTA)

Recommendations for Quality Improvement of the “Foliage Green Thermopro Jacket”

Peckham Industries is a non-profit community vocational rehabilitation organization headquartered in Lansing, Michigan. Founded in 1976, its mission statement is to provide job training and competitive employment opportunities for persons with disabilities, and help maximize human potential. Peckham, Inc. specializes in apparel and general manufacturing as well as business and environmental services; much of its apparel is manufactured for the United States Army.

Our team is working to ensure consistent quality of the Foliage Green Thermopro Jacket produced for the military. The U.S. Army specifies a tolerance of $\pm 1/2$ ” on the dimensions of the finished jacket. Currently, Peckham has determined the starting dimensions for each piece of the garment and uses a standard $\pm 1/4$ ” fault tolerance on all freshly-cut pieces.

Our team plans to determine the cost-effectiveness of the current fault tolerances, examine the cutting gauges, and calculate the optimal fault tolerances for each zone (e.g., front, back, side) of the jacket. We plan to see the effect on cutting and sewing time with increasing the fault tolerance from $1/4$ ” to $1/2$ ”, as well as the amount of scrap generated due to failure of meeting required dimensions. The optimal fault tolerance will be the most cost-effective for Peckham, while minimizing the time spent and waste generated throughout the cutting and sewing processes.



MSU Team Ten
left to right

Stephen Brown, Theresa Hampel, Stuti Sinha, Horacio Munoz, Anu Prasad, Dena Bachi, and Patrick Kelleher (GTA)



BE 485 BIOSYSTEMS DESIGN TECHNIQUES AND BE 487 BIOSYSTEMS DESIGN PROJECT

**PROJECT INSTRUCTOR:
STEVEN SAFFERMAN**



**PROFESSIONAL DEVELOPMENT INSTRUCTOR:
STEVE MILLER**

Biosystems Engineering

Biosystems engineers integrate and apply principles of engineering and biology to a wide variety of socially important problems. The MSU biosystems engineering program prepares graduates to:

- Identify and solve problems at the interface of biology and engineering, using modern engineering techniques and the systems approach, and
- Analyze, design, and control components, systems, and processes that involve critical biological components.

MSU biosystems engineering graduates are having a positive impact on the world, working in areas such as ecosystems protection, food safety and biosecurity, bioenergy, and human health.

Automated Aquaculture Feeding System for Yellow Perch

Yellow perch are in high consumer demand in the northern United States. A commercial fishing ban on yellow perch in the Great lakes has made aquaculture systems a popular source of this fish. Unlike other species, little research has been done to optimize growth of yellow perch in aquaculture farms including the amount of feed, time of feeding, and water quality parameters. This created the need for a data collection system to identify parameters for optimal and healthy fish growth and the development of an optimization approach.

The objectives of the project were to design an automated feeding and sensor system to reduce labor intensity and collect all data needed to create a predictive feeding system (maximizing fish growth while minimizing feed waste). Benefits of optimization include more consumer-acceptable fish and reduction in wasted feed, leading to a higher profit.

An automated feeding system was constructed and placed in a grow-out tank at the sponsor's facility. Sensors were also selected. A harness was built to house the sensors in the tank. Data is collected through LabVIEW, and can be viewed remotely over the web. An email alert will be sent if any parameters are out of bounds. Recommendations on how to proceed with optimization will be made based on a simple nitrogen mass balance and statistical analysis.



Yan Liu



Team Members

Andrew Franco
Dexter, MI

Tara Sliwinski
Fraser, MI

Kevin Swahn
Dearborn Heights, MI

Faculty Advisor

Yan Liu, Dept. of Biosystems and Agricultural Engineering

Steve Marquie, Dept. of Biosystems and Agricultural Engineering

Sponsor

Aquaculture Research Corporation



Steve Marquie

Beneficial Utilization of Apple Pomace by Means of Extrusion and Tray Drying Methods

Introduction and Objectives: PepsiCo has large amounts of fruit and vegetable by-product waste that accumulate each year and are sold as cattle feed. The by-product of apples, known as apple pomace, has significant amounts of total dietary fiber and quercetin. Once stabilized, the pomace can be added as an ingredient to existing and future products for increased nutritional value. The objective of this project is to provide PepsiCo with economic analyses of three processes to stabilize the apple pomace, as defined by reducing the moisture content to less than 10% to inhibit the growth of microorganisms.

Project Design: Three processes will be analyzed for stabilization effectiveness and nutrient content. Cost will be calculated by determining energy usage and equipment specifications. Pomace will be pressed prior to processing for each of the three following processes: tray drying; tray drying and extrusion; tray drying and extrusion with added flour.

Results: A final report with details of the cost and a sensitivity analysis for each process will be provided to PepsiCo. This data can be used as a starting point to decide if it is feasible to stabilize the by-products for future use as an ingredient.



Kirk Dolan



Bradley Marks



Team Members

Juliana Henriques
Sao Paulo, Brazil

Claire Schuurmans
Byron Center, MI

Phil LaMothe
Lake Orion, MI

Pawel Kargol
Canton, MI

Faculty Advisors

Kirk Dolan, MSU, Biosystems
and Agricultural Engineering

Bradley Marks, MSU,
Biosystems and Agricultural
Engineering

Sponsor

PepsiCo

Tank Cleaning System Optimization

Perrigo is the largest manufacturer of private label over-the-counter pharmaceuticals in the United States. Production of a bismuth-based stomach relief medication results in residue buildup on the walls of mixing tanks, necessitating workers to enter the vessel and manually scrub the interior. This practice raises issues such as worker safety and increased production time, labor, and energy costs.

In order to address the cleaning issues, a holistic method was developed that examined both production and cleaning practices. Computational fluid dynamics, a modeling approach involving numerical methods, was used to analyze mixing. In addition, an experimental approach was used to examine how multiple factors affect removing residue build up.

A bench-top experiment was developed in order to simulate the mixing and cleaning process steps. Optimal detergent concentration, time, and temperature were determined through statistical analysis of experimental data, and a mathematical equation was developed describing the impact that each factor has on the cleaning process. Additionally, COMSOL's computational fluid dynamics model was used to improve the quality of mixing, and to determine areas of concern.

After analysis of empirical and theoretical results, recommendations were proposed to improve the manufacturing protocol of Perrigo's bismuth-based, stomach relief medication.

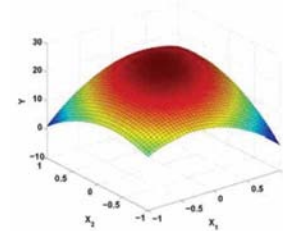

Jim Steffe

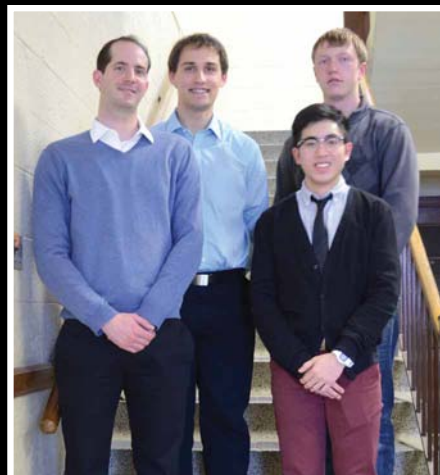

Team Members

Michael Zanotti
Traverse City, MI

Ian Hildebrandt
Ionia, MI

Michael Huarng
Northville, MI

Dylan Comer
Traverse City, MI

Faculty Advisor

Jim Steffe, Department
of Biosystems and
Agricultural Engineering

Sponsor

Perrigo Pharmaceuticals

Integrated Solar Heated Anaerobic Digester and Treatment Wetland

Livestock and agricultural production generate large amounts of organic waste. In Central America, 20% of GDPs are from this sector. Converting this material to clean and affordable electricity through anaerobic digestion can increase the amount of reliable energy available to this region. Anaerobic digestion is the microbial conversion of organic carbon into biogas in the absence of oxygen. Combining this process with solar heating will increase the overall efficiency of the system, creating higher energy yields.

Biogas, a product of digestion, can be combusted to produce energy but typically 30-40% of the biogas produced is used to heat the system, required to maximize biogas yield. The combination of solar heating with anaerobic digestion eliminates the use of biogas for heating, thereby maximizing the amount that can be converted to electricity. Utilizing a treatment wetland in conjunction with anaerobic digestion further reduces the adverse environmental impacts associated with organic waste streams.

Solar heating, anaerobic digestion, and wetland treatments have been extensively studied; however, integration of these components has not. The team designed and constructed a lab-scale system that integrated a solar-heated anaerobic digester and a wetland suitable for digester effluent. Additionally, the team developed a LabVIEW program to monitor and control the system. For the next two years, the system will be used to collect data for feedstock variability and scale-up in Central America.



Wei Liao



Dawn Reinhold



Team Members

Dave Hochhalter
Detroit, MI

Eric Werner
Kalamazoo, MI

Miranda Sperry
Mason, MI

Katie Balaze
Canton, MI

Lauren Deitz
Clarkston, MI

Faculty Advisors

Wei Liao, Department of
Biosystems and Agricultural
Engineering

Dawn Reinhold, Department
of Biosystems and
Agricultural Engineering

Sponsor

US Department of State

Model of Torrefaction Bioenergy System and Supply Chain

Public Act 295 (PA 295), also known as the “clean, renewable and efficient energy act” of Michigan, was signed into law in October 2008. This legislation promotes clean and renewable sources of energy by 2015, and requires providers to deliver 10% of power from renewable resources. Because of PA 295, the burning of biomass, a biological material from plant material, is being considered for use in the current energy generating infrastructure, including coal-burning facilities. Biomass has a lower energy value than coal; however, pretreatment can increase its energy value to become more similar to coal.

Torrefaction is a thermochemical reaction of biomass that produces a water-resistant material with a high energy value. This pretreatment process is being considered because biomass retains 90% of the energy in 70% of the original mass. The product of torrefaction is a hydrophobic, brittle, high-energy material. While torrefaction is a relatively new concept, still in the research phase, a desire exists to better understand the entire bioenergy supply chain. The team’s goal was to create a model to represent the torrefaction bioenergy system from tree harvest to end use in the coal plant.

Information was gathered from external sources and experimental data. This included equipment and operating costs as well as mass and energy balances on the torrefaction system. A final Excel model was produced in which users can input energy requirements or available harvesting land to understand the requirements to support their bioenergy system. The end user of this model will likely be an individual or group considering the use of torrefied biomass as an energy source.

Mass Balance on each component of system

Woods/Cultivation			
Inputs	Units	Amount	Outputs
Plaster	kilograms	1000	Raw Biomass
Willow	kilograms	1000	Ag. Run-off
Fertilizer 1	kilograms	100	Surface water run-off
Pesticide 1	kilograms	200	
Water	kilograms	300	
Fuel	kilograms	400	
Harvesting			
Inputs	Units	Amount	Outputs
Fuel	kilograms	1000	Raw Biomass
Chipping			
Inputs	Units	Amount	Outputs
Raw Biomass	kilograms	1000	Raw Biomass
Transportation A&B			
Inputs	Units	Amount	Outputs
Fuel	kilograms	1000	Water
Dryer			
Inputs	Units	Amount	Outputs
Raw Biomass	kilograms	1000	Water
	kilograms		Dry Biomass
Heating value of off-gas stream to see if energy sufficient to dry and torrefy biomass			
Torrefier(s)			
Inputs	Units	Amount	Outputs
Dry Biomass	kilograms	100	Torrefied Biomass
Air (Excess)	kilograms	100	Off-gas
Nitrogen	kilograms	100	
	Torrefied yield vs. temperature vs. res. Time		*bridgeman yield as a %
Blender			
Inputs	Units	Amount	Outputs



Chris Saffron



Team Members

Jessica Emery
Rockford, MI

Lara Ejups
Bay Shore, NY

Corey Scheffler
St. Joseph, MI

Kevin Messing
Ubyly, MI

Faculty Advisor

Chris Saffron, Department of
Biosystems and Agricultural
Engineering

Sponsor

Mark Seamon
MSU Extension

Water Purification System for a Developing Country

Michigan legislation calls for displacement of coal in power plants, requiring a percentage of energy be produced from renewable sources. Burning biomass is an option. However, biomass has a lower energy value than coal.

Over 1 billion people, typically in the developing world, do not currently have access to safe drinking water. The poorest inhabitants of the world survive on less than \$2 a day and live where average conditions do not provide for adequate wastewater treatment and sanitation. This lack of access leads to widespread illness, disease, and death.

Teaming up with Aqua Clara International, a non-profit organization based in Holland, MI, the team worked to develop a community-sized water purification system. This system will provide 4,000 liters per day for a developing country. Aligning with the goals of ACI, the water must be clean and safe according to the World Health Organization standards, cost less than \$0.001 per liter to operate, and be effectively utilized by the local residents.

A system was created that incorporated a primary filtration method and secondary disinfection component. The primary filtration method is a sand filter and the secondary disinfection component is an ultra violet light system. A prototype was constructed to perform tests on. The team hopes to travel to Nicaragua in May to implement the system at a location familiar to Aqua Clara International.

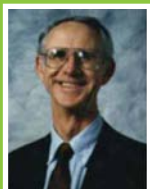

Theodore Loudon



Team Members

Lindsay Reynolds
Royal Oak, MI

Megan Robb
Gaylord, MI

Sarah Fink
Wixom, MI

Faculty Advisor

Theodore Loudon
MSU, Biosystems and
Agricultural Engineering

Sponsor

Aqua Clara International

Eutrophic Pond Restoration and Toxic Cyanobacteria Mitigation

For Better Independence, a non-profit organization located in Leslie, Michigan, is losing useable land due to the excessive expansion of an existing pond-wetland system, resulting in economic loss. Furthermore, excess nutrient inputs have resulted in highly eutrophic conditions in the body of water, therefore raising concerns of toxic cyanobacteria blooms, negating its use.

The team's project design was three-fold: restoring the pond to non-eutrophic conditions, reclaiming land, and mitigating potential health risks from toxic cyanobacteria through prevention and detection.

To restore the pond system to initial capacity, a stretch of effluent tile drain was identified for replacement. A vegetative buffer strip and best management practices were developed to rehabilitate the ponds to non-eutrophic conditions. Furthermore, the team has researched and recommended cyanobacteria inhibition methods along with a decision tree to identify the potential presence of toxic cyanobacteria, which can be implemented immediately.



Dawn Reinhold



Team Members

Bill Stieber
Harrisonburg, VA

Jeff Crandell
Grand Blanc, MI

Emily Campbell
Fraser, MI

Gretchen Merkel
Marshall, MI

Joe Horbatch
Northville, MI

Faculty Advisor

Dr. Dawn Reinhold
MSU, Biosystems and
Agriculture Engineering

Sponsor

For Better Independence
Leslie, Michigan



CE 495 SENIOR DESIGN IN CIVIL ENGINEERING

FACULTY ADVISORS: Professors: Baladi, Hashsham, Kodur, Maleck and Wallace



Baladi



Hashsham



Kodur



Maleck



Wallace

Student-teams developed preliminary designs for elements of MSU’s Facility for Rare Isotope Beams (F-RIB) – the \$550 million cutting-edge research facility to advance understanding of rare nuclear isotopes and the evolution of the cosmos. As envisioned in this planning exercise, construction of the facility would include the design of a new building and the deep excavation for the 1000 foot long linac tunnels, permanent removal of Bogue St. between Shaw and Wilson, and development of a storm-water runoff plan to reduce impacts of the urbanized campus on the Red Cedar River. The feasibility of providing an upgraded waster water treatment plant is being investigated. Teams developed preliminary plans for the following civil engineering issues: temporary excavation shoring and utility bridging required to construct the linac tunnels; maintenance of campus vehicular and pedestrian traffic; post construction storm water management.

PROFESSIONAL EVALUATORS

Engineers and scientists associated with the following firms, municipalities, and companies donated time to provide students with a practicing professional’s perspective: Bergmann Associates; Consumers Energy; DC Engineering; East Lansing Dept. of Public Works; Fishbeck, Thompson, Carr & Huber; HNTB; NTH Consultants; Soil & Materials Engineers; Tetra Tech MPS; URS Corporation; and Wilcox Professional Services. We gratefully acknowledge their generous contributions.

Rick Chelotti, PE
*Bergmann Associates
Lansing, MI*

Peter Margules, PE
*NTH Consultants
Northville, MI*

Anthony Thomas, PE
*Soil & Materials Engineers
Shelby Twp., MI*

Daniel Christian, PE
*Tetra Tech MPS
Lansing, MI*

George McKenzie, PE
*NTH Consultants
Lansing, MI*

Phil Vogelsang, PE
*URS Corporation
Grand Rapids, MI*

Matt Junak, PE
*HNTB
E. Lansing, MI*

John Saller, PE
*Wilcox Prof. Services, LLC
Lansing, MI*

Kurt Krahulik, PE
*DC Engineering
DeWitt, MI*



Todd Sneathen, PE
*Director of Public Works
E. Lansing, MI*

John LeFevre, PE
*FTCH, Inc.
Lansing, MI*

Michael J. Thelen, PE
*Soil & Materials Engineers, Inc.
Lansing, MI*

Thiru Thiruvengadam, PhD, PE
*Consumers Energy (retired)
Okemos, MI*

Award Sponsors

CE 495 SENIOR DESIGN IN CIVIL ENGINEERING



Team 1: Creative Solutions Engineering I-r: Collin Hubbell, Aaron Wendzel, Cameron Williams, Andrew Newell, Andrew Block, Daniel Tsai, Zachary Underwood



Team 2 Collaborative Industries: I-r: Lauren Kutskill, Madlyn Moellering, Alex Jakstys, Michael Foster Murray, Rob Oikernan, Ani Heeringa

Team 1
8:00 a.m.
MSU Room

Team 2
8:00 a.m.
Lake Michigan Room



Team 3: Great Lakes Consulting I-r: Trent Powers, Jake Formanczyk, Matt Wagner, Ben Rausch. Bottom Left to Right: Greg Waite, Catherine Osborn, Kevin Reschke.



Team 4: GreenWay Engineering I-r: Nicolas Lebel, Charmane Carruthers, Ryan Brown, Nick Ballou, Aaron Stinson. (Not pictured: Mitch VanPortfleet, Derek Raska)

Team 3
9:20 a.m.
MSU Room

Team 4
9:20 a.m.
Lake Michigan Room

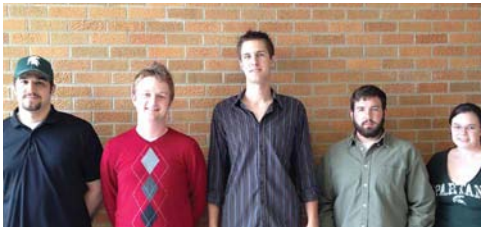

Team 5: Stonehenge Engineering Inc. Back, I-r: Keith Cox, Greg Siviuy, Gerrit Littrup, Luke Biernbaum, Darcy Christian. Not pictured: Katelyn Pomaville



Team 6: Topt Engineering Back, I-r: Ian Neerken, Tyler Smith, Brandon Maurer, Adam Klein. Front I-r: Yishi Huang, Jun Deng

Team 5
10:40 a.m.
MSU Room

Team 6
10:40 a.m.
Lake Michigan Room

CIVIL ENGINEERING SENIOR DESIGN AWARD

The Civil Engineering Senior Design Award (\$700 and plaques) is presented to the best team as judged by the faculty and a panel of practicing engineers.

Each team is responsible for developing a design that addresses environmental, geotechnical, hydrological, pavement, transportation, and structural issues for the project. A student project manager coordinates each team. Design reports are judged by the faculty; progress reports and the oral presentations are judged by a board of practicing professionals.

The faculty and students of the Department of Civil and Environmental Engineering gratefully acknowledge the generous contributions from Fishbeck, Thompson, Carr & Huber, Inc. (FTC&H) and from Barr Engineering Co. These companies currently make this award possible. FTC&H is a professional civil engineering, environmental consulting, architectural/engineering, and construction management firm with clients in Michigan and throughout the nation. Barr Engineering is a professional engineering company providing engineering, environmental, and information technology services to clients across the nation and around the world.

CE 495 Senior Design in Civil Engineering

Undergraduates in civil engineering must take CE 495. This capstone course prepares students for the work place by providing an experience with the following challenges:

- A project with multiple issues that must be resolved using civil engineering knowledge;
- Formulation of conceptual solutions and resolution of conflicting design elements;
- Development of plans that comply with regulations and provide a basis for cost estimates;

- Balancing individual responsibility and group participation in a team based effort;
 - Preparation of written reports and oral presentations.
- Engineers and scientists associated with the following firms, municipalities, and companies donated time to provide students with a practicing professional's perspective: Bergmann Associates; Consumers Energy; DC Engineering; East Lansing Dept of Public Works; Fishbeck, Thompson, Carr & Huber; HNTB; NTH Consultants; Soil & Materials Engineers; Tetra Tech MPS; URS Corporation; and Wilcox Professional Services. We gratefully acknowledge their generous contributions.

ChE 434

8:00 a.m.-Noon
First Floor
Lounge



ChE 434: PROCESS DESIGN AND OPTIMIZATION II

INSTRUCTOR:
Professor Martin Hawley

COURSE ASSISTANT:
Andrea Orjuela

Course Description:

ChE 434 is a logical extension of the first semester of chemical engineering senior design. The abilities developed over a wide range of chemical engineering courses are now applied to a problem extending over a somewhat longer period of time; requiring more initiative, enterprise, care and a greater measure of individual responsibility. For the 43rd successive year, we have worked the American Institute of Chemical Engineering (AIChE) Student Contest Problem. We use these industry-designed problems for three reasons: 1) they are well-rounded problems, 2) they tell our students and our faculty something about the kind of abilities that industrial companies would like graduating chemical engineers to have, and 3) there is the advantage of seeing how well our students compare with graduates of other universities in a national competition of this quality.

For Design Day, five Teams and five Individuals were chosen to present their designs via a poster presentation. From this final group, two teams of two, and two individuals will be chosen to compete in the national AIChE competition in the fall. Since 1968, about half of the students whose reports rated first or second at MSU also finished among the top six nationally.

Last Year's Winners!

Two of the students who presented at last Spring's Design Day received top honors in the 2011 AIChE National Student Design Competition. Nathan Hanna won first place in the individual competition, and Nathaniel McIntee-Chmielewski received an honorable mention in the same category.

Both of these students were able to travel to Minneapolis in October 2011 to present their solutions at the AIChE National Meeting.



Nathan Hanna



Nathaniel McIntee-Chmielewski

AIChE®

PROBLEM STATEMENT:

Non-Alcoholic Beer Plant Design

The objective of this year's AIChE Design Problem was to evaluate the economics of the production of non-alcoholic beer in five different states: Alabama, Georgia, California, Florida and Texas, using a reverse osmosis membrane process.

The targeted breweries were considered to be able to produce 60,000 barrels/year (BPY) and to have an excess capacity up to 30,000 BPY. The students were required to determine the minimum capacity of non-alcoholic beer (above 60,000 BPY of alcoholic beer) that provided an IRR of 15%, as well as the capacities required to achieve IRR's of 20%, 25%, 30%, and 35%.



(l-r): Daniel Keen and Robert Hasselbeck

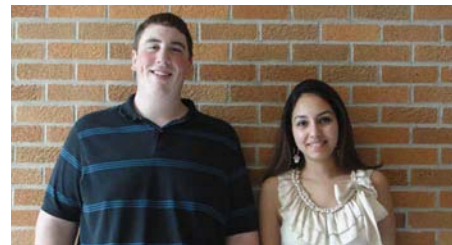

(l-r): Jacob Wilkinson and Hela Ben Hadj



(l-r): Joseph Riggs and Timothy Chien



(l-r): Mathew Franklin and Mohammad Fassia

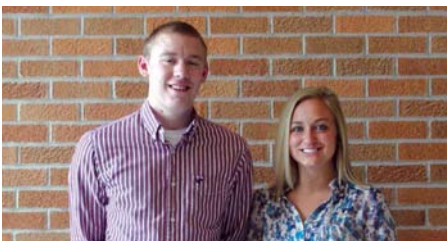

(l-r): Nicholas Lamb and Ramy O'Keefe



Alexander Smith



Cristopher Beuerle



Daniel Lenders



Kara Vossler



Patrick Walsh

MSE 466

8:00 a.m. – Noon
First Floor
Lounge



SENIOR DESIGN CAPSTONE IN MATERIALS SCIENCE AND ENGINEERING

INSTRUCTOR: Prof. James P. Lucas

TA Staff: Xiaofeng Fan

Course Statement

MSE466 is a senior course for Materials Science & Engineering majors providing students with a team-based capstone design experience. A major aspect of this course is to have students apply their course-learned background knowledge and skills in materials science and other disciplines to real-life design problems. A failure analysis investigation (FAI) fits this context. Failures are a major motivating factor for promoting more innovative designs or design changes. A failure analysis investigation provides a unique platform to design and to solve real-world engineering problems via systematic engineering approach. By focusing on a specific design failure, the student teams learn how to confront an open-ended problem that requires them to develop a strategic design plan and to execute the methodology for assessing how and why the failure occurred. The analysis is conducted using established investigative procedures and constraints for conducting failure analysis investigation. This semester, there are six 4-5 member teams working on six real engineering failures.

Successfully completed team projects culminate in a comprehensive written final report and a strategic redesign plan to improve the design and mitigate future failures. The teams will give poster presentations that summarize their findings. For 2012, six teams are conducting an FAI on the following project titles:



Team M1:

l-r: Chantelle Pline**
Matt Cumming
Andrew Seymour
Nikki Koivunen
(*team leader)

Project: Failure by Crack Propagation in Al-Alloy Softball Bat

Team M1: 'PLAYERS'

Macroscopic examination of the aluminum softball bat showed multiple crack fractures spanning the length of the barrel to the top of the handle. Preliminary FAI results also indicated that the failure occurred by a brittle fracture mode. Early assessment suggested that factors associated with materials selection and manufacturing processes are at issue.



Team M2:

l-r: Stephanie Bergman
Mike Parr**
Doug Schriner
Dani Curran
(*team leader)

Project: Carver Bench-Top Laboratory Bolster Platen Failure

Team M2: 'SPARTAN'

Vendor information and specifications rate the bench-top press at a 12-ton limit. Initial examination showed the cross-bar press platen failed by crack initiation on its top surface. The extent of cracks noted in the failure suggested the system was loaded to high stress level. Several approaches are under consideration including overloading misalignment and material integrity.

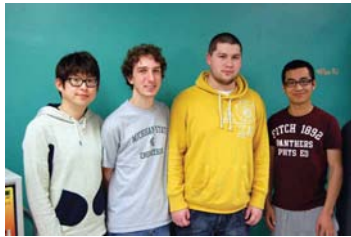

Team M3:

l-r: Chan Jaegal
Scott Sutton**
Andrew Rauch
Guangnian Yang
(*team leader)

Project: Outdoor Sprinkler System Brass Gate Valve Fracture

Team M3: 'TEAM SEVEN'

Macroscopic visual examination showed that failure of the brass gate valve and its body was due to crack propagation possibly due to stress corrosion cracking (SCC). The valve system was exposed to seasonal temperature changes (0 – 90 F) and to the elemental chemistry and deposits of tap water. Material degradation (@ dezincification) is being considered as a possible failure source.



Team W1:

l-r: Kaitlin Tyler**
Marc Benjamin
Isabel David
Jeff Cain
(*team leader)

Project: Failure of Rear Brake Rotor – 2002 Jeep Grand Cherokee

Team W1: 'ARCTIC PANDAS'

Visual examination revealed failure by cracking of the brake rotor. The fracture occurred at the joining of the rotor flange and hub. The rotor was manufactured from graphite-flaked cast iron and the nature of the fracture was brittle. Preliminary evidence suggested that the main, critical crack initiation site for the rotor was due to premature nucleation of micro-cracks at graphite flake agglomerates in the material.

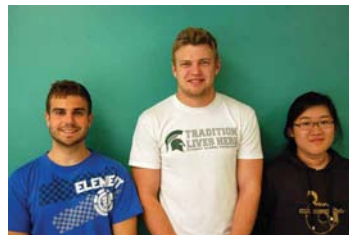

Team W2:

l-r: Mark Dawson**
Derek Sabiston
Menge Zhao
(*team leader)

Project: Failure of A Cadillac ATS Steel Propshaft Sub-Assembly

Team W2: 'FAILURES'

The Alpha propshaft rear assembly failed under cyclic torsional loading prior to the loading life cycle requirement. The function of this shaft is for power transmission to the rear drive module. Several joining techniques were apparently used to assemble the propshaft couplings. The most prominent joining methods are spot and friction welding. Consequently, welding-related manufacturing issues are being critically investigated.



Team W3:

l-r: Pat Mann**
Chris Kuenning
Camilla Cendraguinassi
Alfonso Muineloherranz
(*team leader)

Project: Fracture Analysis of a Bowl Die used in 15-Ton Hydraulic Press

Team W3: 'LEOPARD'

The M4 tool-steel bowl die is installed in a high-capacity 15-ton hydraulic press. The die is used to stamp parts for the steering column in the automobile industry. Brittle fracture failure of the bowl die assembly occurred after only 3,500 of the specified 10,000 stamping cycles. Examination of the fracture surface indicates rapid crack propagation during the failure as some evidence of Wallner lines was apparent.

Computer Science and Engineering

Capstone Course Sponsors

We thank the following companies for their generous support of the computer science capstone course.

Auto-Owners Insurance
Lansing, Michigan



The Boeing Company
St. Louis, Missouri



The Dow Chemical Company
Midland, Michigan



GE Aviation
Grand Rapids, Michigan



Meijer
Grand Rapids, Michigan



Motorola Mobility
Libertyville, Illinois



Mozilla Corporation
Mountain View, California



Plex Systems
Auburn Hills, Michigan



Raytheon
Fort Wayne, Indiana



Spectrum Health Systems
Grand Rapids, Michigan



TechSmith
Okemos, Michigan



Urban Science
Detroit, Michigan





Computer Science and Engineering Capstone Course Projects

Presentation Schedule – Lake Ontario Room
Dr. Wayne Dyksen
Professor of Computer Science and Engineering

Time	Team	Project Title
7:30 a.m.	Auto-Owners	Enterprise Learning Management System
7:50 a.m.	Boeing	Design, Fly and Compete Flight Simulator
8:10 a.m.	Dow	Global Water Dashboard
8:30 a.m.	GE Aviation	Mobile Avionics Weather
8:50 a.m.	Meijer	Food Safety Audits and Reports
9:10 a.m.	Motorola Mobility	Context-Driven Content Delivery
9:30 a.m.	Break	
9:45 a.m.	Mozilla	In-Content Preferences for Firefox
10:05 a.m.	Plex Systems	HTML5-Based WYSIWYG Label Designer
10:25 a.m.	Raytheon	Android VoIP Communications System
10:45 a.m.	Spectrum Health	Web Applications for Healthier Communities
11:05 a.m.	TechSmith	Mobile Smart Video Player
11:25 a.m.	Urban Science	Infographics Generator

CSE 498 Collaborative Design

CSE 498, Collaborative Design, provides the educational capstone experience for all students majoring in computer science. The course objectives include the following:

- Designing, developing, and delivering a comprehensive software system to a client;
- Learning to work effectively in a team environment;
- Developing written and oral communication skills;
- Becoming proficient with software development tools and environments;
- Learning about system building and system administration; and
- Considering issues of professionalism and ethics.

Project sponsors are local, regional, and national, and have included Auto-Owners Insurance, Boeing, Chrysler, Dow, Ford, GE Aviation, General Motors, IBM, Meijer, Microsoft, Motorola Mobility, Mozilla, Plex Systems, Raytheon, Sparrow Health System, Spectrum Health Systems, TechSmith, Terex, Toro, Two Men and a Truck, the Union Pacific Railroad, and Urban Science.

The Capstone Experience Lab Sponsored By



URBAN SCIENCE.

We thank Urban Science for their generous support of the Capstone Experience Lab.



Auto-Owners Insurance Enterprise Learning Management System

Auto-Owners Insurance provides its associates many opportunities for professional development, which include courses and certifications from a variety of vendors. Our Enterprise Learning Management System (ELMS) is a web-based application designed to manage the entire professional development program of Auto-Owners.

Based on a system called Moodle, our ELMS is tailored specifically to the needs of Auto-Owners. Extensions to Moodle provide functionalities and features customized for associates, managers, and instructors, all through a web browser. Courses from many organizations such as Institute of Internal Auditors and the Life Office Management Association are integrated seamlessly providing one-stop shopping.

Our ELMS enables Auto-Owners associates to manage their own professional development. They enroll themselves in courses, view class materials, take tests, view test results, and track their progress towards each designation or certification, all within a single, user friendly web application.

Managers and instructors monitor the progress of associates, making recommendations and generating reports.

Our extensions to Moodle are easy-to-install plug-ins, making the customization of Moodle simple and easy for Auto-Owners Insurance to maintain.

Moodle is an open-source software package. Our custom extensions are written in PHP 5 and JavaScript.

Auto-Owners ELMS You are logged in as John Doe (Logout)

Home > Site pages > Designation Tracking

Main menu

- Ad-Hoc Reports
- Grade Importing
- Designation Tracking
- Course Registration
- Site news

Navigation

- Home
- My home
- Site pages
- My profile
- Courses
- Users

Designation Tracking

Top Designation Progress

Associate in Risk Management	100%
Associate in Underwriting	100%
Associate in Insurance Accounting & Finance	75%
Chartered Financial Consultant	50%
Associate, Customer Service	50%
Completion of all four Intro Courses	25%

Individual Designation Progress

Associate in Insurance Accounting & Finance

IIA

Code	Test Number	Status
AIAF 111	111	✓
AIAF 111	111	✓
AIAF 112	112	✓
AIAF 113	113	✗



Michigan State University Team Members (left to right)

Christopher Marsh
Royal Oak, Michigan

Preston Skupinski
South Lyon, Michigan

Fai Hui Wu
Warren, Michigan

Auto-Owners Project Sponsors

Tom Beaudoin
Lansing, Michigan

Bob Buchanan
Lansing, Michigan

John Kirk
Lansing, Michigan

Scott Lake
Lansing, Michigan

Jana Peeples
Lansing, Michigan

Jim Schumacher
Lansing, Michigan

The Boeing Company

Design, Fly and Compete Flight Simulator

The Boeing Company is a world leader in commercial and military aircraft. They utilize complex simulation software to design and develop their products to explore how changes in design affect performance.

In order for simulations to give accurate predictions of performance, they must be a very accurate representation of actual flying conditions. Our Design, Fly and Compete Flight Simulator provides a plane flight simulator with a strong flight model, using six degrees of freedom for motion.

Our flight simulator features a progression system in which the user completes a series of obstacle courses, challenging their flight skills in order to unlock additional courses as well as improve their completion times.

The user starts the program and enters their user name, which is used to track their progression, as well as scores on courses.

The user can choose from any of the courses available to them and see their previous best result. They can choose to run through a course in the simulator to improve their result or complete it for the first time, thereby furthering their progression through the course system.

The obstacle courses consist of a series of floating rings that must be flown through in the correct order. The rings are arranged to present various challenging maneuvers.

The program uses the Qt framework for Windows. The 3D environment is rendered by OpenSceneGraph.

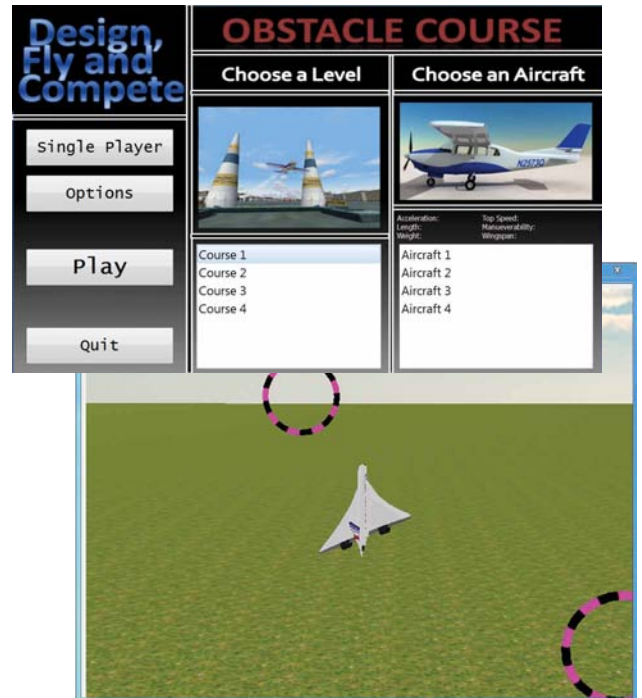

Michigan State University Team Members (left to right)

Brandon Overall
Walled Lake, Michigan

Jon Moore
Fort Wayne, Indiana

David Cornelius
Blue Springs, Missouri

Boeing Project Sponsors

Pete Clive
Saint Louis, Missouri

Matt Daniels
Saint Louis, Missouri

Jayson T. Vincent
Saint Louis, Missouri

Steve Yallaly
Saint Louis, Missouri

The Dow Chemical Company Global Water Dashboard

While seemingly plentiful, water is not an unlimited resource. Without constant monitoring and proper planning, the demand for water can outpace the supply. Hence, the Dow Chemical Company continually observes water intake and stress levels at their plants throughout North America.

Our Global Water Dashboard is an interactive dashboard that enables Dow to analyze the water intake of their various manufacturing sites from a water basin.

The landing page of our dashboard shows a visualization of all the data with graphs and charts, such as manufacturing units located in water stressed regions, water intake levels, and a comments section to capture water related information such as completed or planned projects and awards received.

From the landing page, the user can move to the map page where the user can select sites by geographic region and view the relevant water related information. The user can then choose one or more sites for viewing the site-specific data or generating a report.

Reports can be viewed by the user on the reports page where the user can compare one or more sites based on years or other fields such as water intake type and water projects.

Our Global Water Dashboard is built in Microsoft SharePoint using Silverlight integration for Bing Maps. Sequel Server Reporting Services (SSRS) is used to generate the reports. The landing page is generated by PerformancePoint.

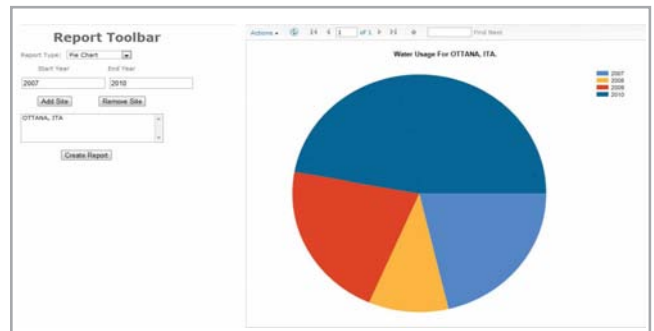
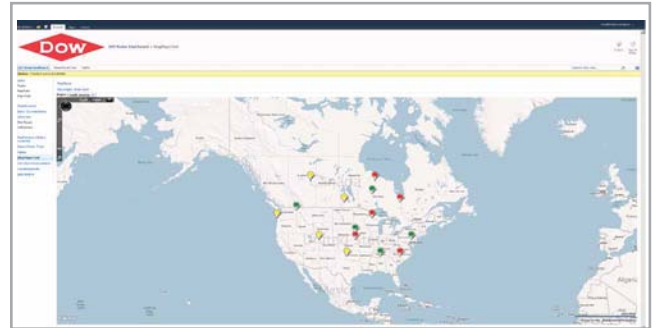

Michigan State University

Team Members (left to right)

Nate Henry
Okemos, Michigan

James Solomon
Grand Ledge, Michigan

Anthony Curley
Rochester Hills, Michigan

Dow

Project Sponsors

Dave Asiala
Midland, Michigan

Martin Brennan
Midland, Michigan

Jim Nesbitt
Midland, Michigan

Jeremy Preston
Midland, Michigan

Dave Ross
Midland, Michigan

GE Aviation Mobile Avionics Weather

Pilots and air traffic controllers must have accurate up-to-date weather information both for pre-flight planning and in-flight navigation to ensure the safety of passengers and crews.

Currently, aviation professionals carry all of the necessary charts and maps in paper form. These paper charts and maps contain vital weather information such as barometric pressure, wind speeds, cloud cover and other important data relevant to their flight path.

Recently, the Federal Aviation Administration (FAA) has approved the use of iPads by pilots on the flight deck. Cutting-edge mobile technologies can now be used to provide innovative replacements for outdated technologies along with a host of new ones.

Done in collaboration with GE Aviation, our mobile aviation weather iPad application serves as a replacement for traditional paper weather charts and maps.

FAA aviation maps called sectional charts display a pilot's current location. Up-to-date weather and radar data from the National Oceanic and Atmospheric Administration (NOAA) are overlaid in a user-friendly way. Weather radar animations show the speed and direction of moving weather fronts.

Our mobile avionics weather iPad application is written in Objective-C. The aviation sectional charts are obtained from the FAA. The weather information is acquired from NOAA via RESTful web services.

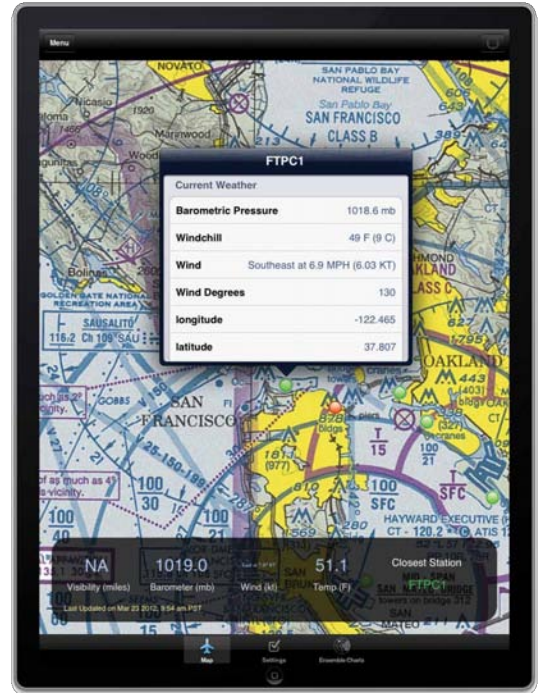

Michigan State University Team Members (left to right)

Mike Dunn
Alto, Michigan

Eric Cook
Grandville, Michigan

Andrew Space
Traverse City, Michigan

GE Aviation Project Sponsors

Serge Badiane
Grand Rapids, Michigan

Steve Carlson
Grand Rapids, Michigan

Dashiell Kolbe
Grand Rapids, Michigan

Brian Loyal
Grand Rapids, Michigan

Meijer

Food Safety Audits and Reports

Meijer is a family-owned chain of supercenters committed to providing quality food and products to its customers all across the Midwestern United States. Health and food safety standards are an important part of the culture at Meijer.

Meijer has two types of health and food safety inspections, internal and external. Meijer employees complete internal audits with each department being graded with an effectiveness score. External audits are conducted by local, state, and food safety agencies like the USDA.

Currently, internal audits are done by paper and pencil. The resulting audits must be entered subsequently into a computer database. Safety violations are counted manually.

Our Food Safety Audits and Reports system replaces the pencil and paper system with a web-based system.

A tablet-based web application is used by internal inspectors within each store. Upon completion, the results of the inspection are automatically uploaded into Meijer's central health and food safety database.

A second web application is used by Meijer managers to view and print reports. The reports are generated by store, based on a specified date range. The reports can be viewed and printed.

Our web applications are written using HTML 5, Java Script, ASP.NET, and C#. Microsoft SQL Server 2008 is the database engine. Reports are generated using SQL Server Reporting Services.

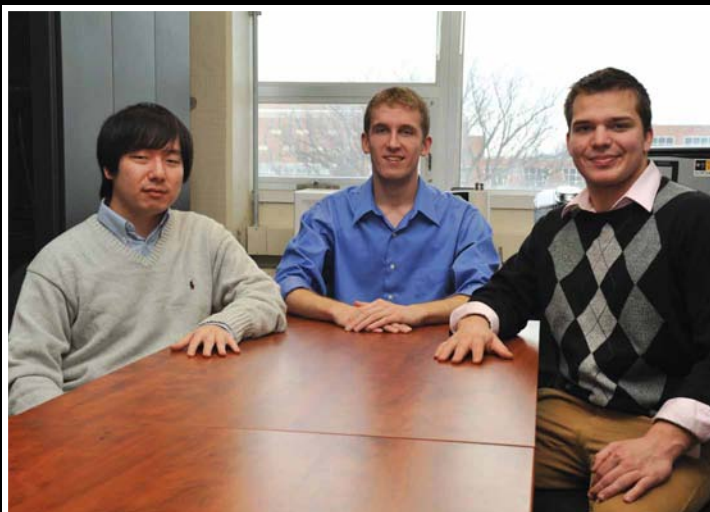
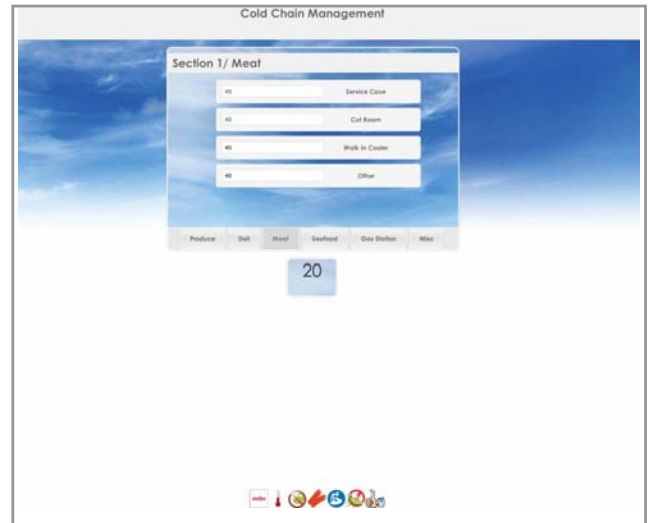

Michigan State University

Team Members (left to right)

WooSeok Chung
Seoul, South Korea

Kyle Hine
Jackson, Michigan

Patrick Bruening
Elk Rapids, Michigan

Meijer

Project Sponsors

Heather Bausick
Grand Rapids, Michigan

Randy Brower
Grand Rapids, Michigan

Jaya Das
Grand Rapids, Michigan

Fred Gross
Grand Rapids, Michigan

Jim Poll
Grand Rapids, Michigan

Dave Rodgers
Grand Rapids, Michigan

Motorola Mobility

Context-Driven Content Delivery

As the mobile device market continues to grow, consumers are using smart phones and tablets more and more in everyday situations.

Compared to the rapid innovations of most technology, the television viewing experience has hardly changed.

The Context-Driven Content Delivery system provides an interactive television experience. As the viewer is watching a television show, the CompleteTV Android application can display other forms of content relevant to what is currently playing on the television.

Content providers have the ability to market their products to targeted audiences by utilizing the system. For example, a content provider could set an advertisement for Walmart as soon as a character on television walks into a Walmart store.

The viewers can synchronize their mobile devices through their cable box at home or, if they are out of range of their cable box, through recording an audio sample from the program that is being viewed. The user also has the option to manually select the program from the Android application.

The Context-Driven Content Delivery system is created using Java along with the RESTful web framework and PostgreSQL. Our mobile applications are written in jQuery Mobile for optimal user experience. These applications are deployed on a Glassfish server and are optimized for the Motorola Xoom tablet device.

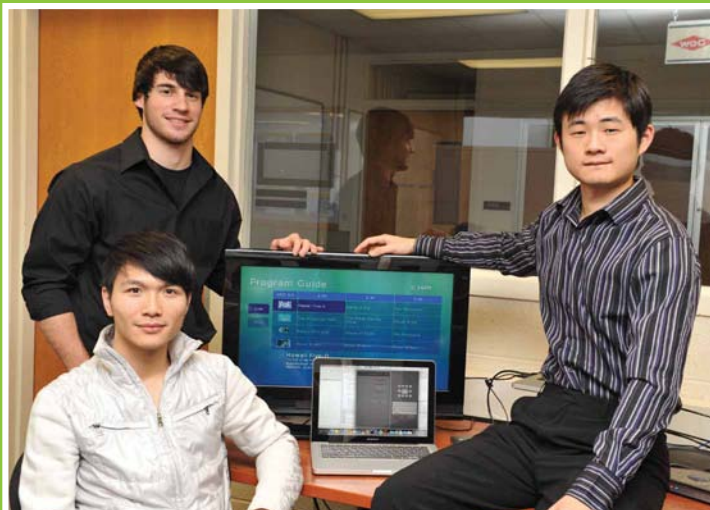

Michigan State University Team Members (left to right)

Yudong Yi
Shenzhen, Guangdong, China

Cory Harter
Holland, Michigan

Linwei Zhu
Hefei, China

Motorola Mobility Project Sponsors

Krunal Shah
Libertyville, Illinois

Kabe VanderBaan
Libertyville, Illinois

Mozilla Corporation In-Content Preferences for Firefox

Firefox is a free and open source web browser that is managed by the Mozilla Corporation. As with all web browsers, Firefox provides users the ability to customize their experience by setting browser preferences such as selecting a homepage.

In the current version of Firefox, the controls for browser preferences are located within a pop-up window that is separate from the main Firefox window.

In their efforts to continually improve upon the web browsing experience, the Firefox User Experience team at Mozilla is working toward the goal of eliminating all pop-up windows. These will be replaced with in-content designs that appear within the main Firefox window, as shown at the right.

Done in collaboration with Mozilla, our in-content preferences for Firefox transition all of the Firefox preferences into a new in-content page within the browser. A new search feature enables users to easily find where to set particular preferences.

Utilizing an in-content design provides several benefits. The need for another easy-to-lose window is eliminated, and the experience of setting preferences is made identical across all devices. Users can more easily experiment with preferences since they can continue to use Firefox while setting preferences. Our new in-content preferences utilize XHTML and XUL to define the structure and controls on the page, CSS for visual styling and element placement, and JavaScript to specify interactive functionality.

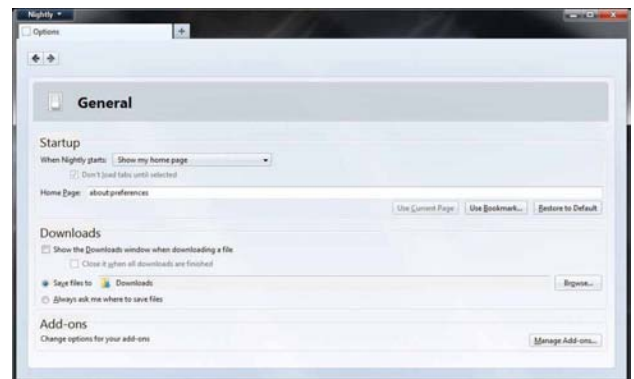
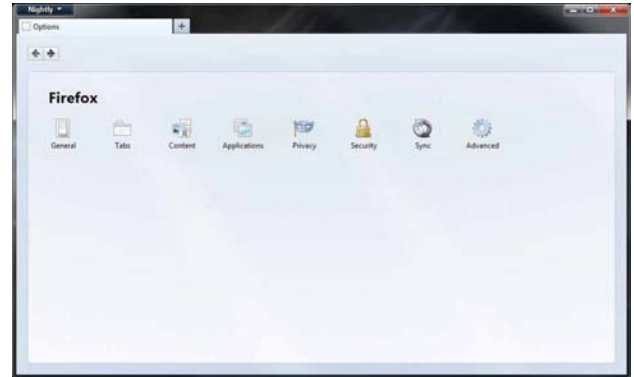

mozilla
Firefox

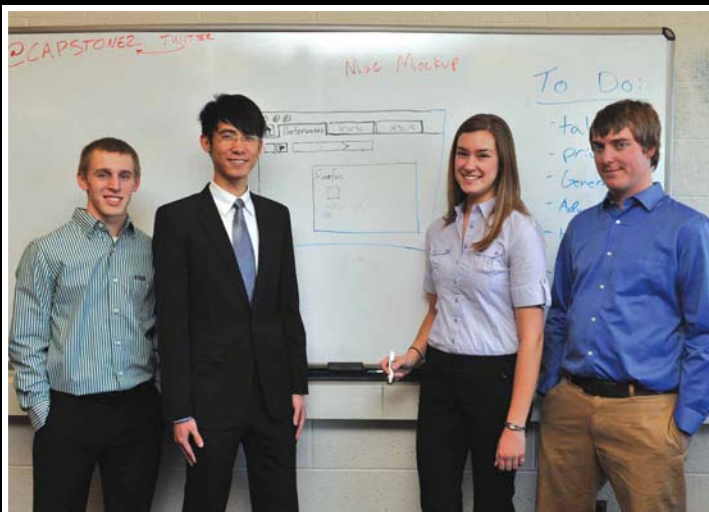

Michigan State University Team Members (left to right)

Jon Rietveld
Holland, Michigan

Zuhao Chen
Guangzhou, China

Devan Sayles
Livonia, Michigan

Owen Carpenter
Ann Arbor, Michigan

Mozilla Project Sponsors

Julie Deroche
Mountain View, California

Blair McBride
Dunedin, New Zealand

Jared Wein
Mountain View, California

Plex Systems

HTML5-Based WYSIWYG Label Designer

Plex Systems is a cloud-based service provider, which offers manufacturing information technology systems to clients in a number of different industries.

A challenge for any cloud-based service is ensuring the ease of customizability of business processes to end users. One such challenge comes from creating additional customized formats for shipping labels.

Currently, the creation of a new format for a shipping label is a manual multi-step process. A customer must first lay out the desired design on paper, measure where element locations are to be placed, and provide detailed textual information describing the label to Plex. Subsequently, Plex must manually enter this information into the customer database, after which that label becomes available for use by the customer.

To simplify this process, our HTML5-Based WYSIWYG (What You See Is What You Get) Label Designer allows customers to create and format labels directly in a web application. These labels are saved into the customer database in the appropriate format for immediate use. Our software eliminates the hand work and enables customers to have direct control over which labels are available to them without required intervention by Plex.

Our HTML5-Based WYSIWYG Label Designer is built using HTML5 and JavaScript, and designed to run in common web browsers. Label layouts are stored in a SQL database using SQL Server 2008 and retrieved using JSON and ASP.NET.

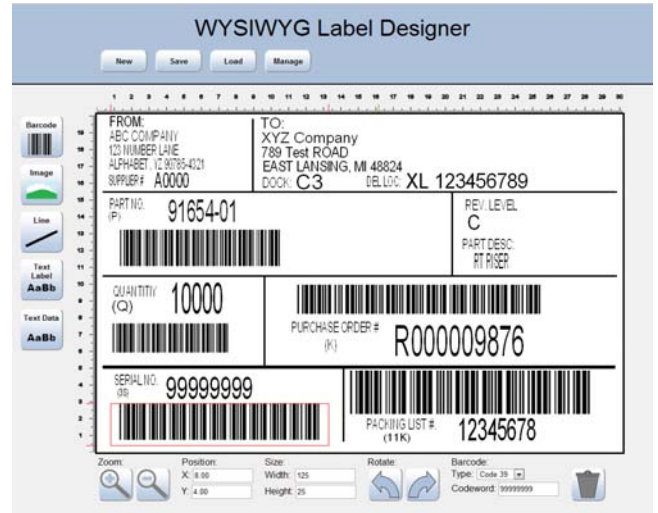

Michigan State University
Team Members (left to right)

Matthew Duffy
Manchester, Michigan

Michele Winsky
Morrice, Michigan

Andrew Melfi
East Lansing, Michigan

Plex Systems
Project Sponsors

Katie Greiner
Auburn Hills, Michigan

Lane Johnston
Auburn Hills, Michigan

Taya Johnston
Auburn Hills, Michigan

Jason Prater
Auburn Hills, Michigan

Toulor Xiong
Auburn Hills, Michigan

Raytheon Android VoIP Communications System

Voice communication is an essential feature for command and control (C2) applications used in emergency management situations or combat settings. The Android VoIP Communications System enables mobile C2 users to transmit critical information over multiple voice channels and thereby exchange information efficiently and effectively.

Our system provides both one-to-one communication and group collaboration. The latter enables tactical operations centers to provide groups of personnel with situational awareness data quickly.

In addition to beginning and ending calls, our system also allows one user to invite another user onto an existing call. A separate desktop application enables users at operation centers to participate in calls, and to listen to previously recorded conversations.

In an effort to simplify radio configuration in a C2 setting, the system also allows radios to be configured in a hands-free manner. Nearby radios can be configured with appropriate voice commands. A confirmation message is sent back to the Android phone for the user to verify the current state of a reconfigured radio.

Our Android VoIP Communications System is developed with the Android SDK. Calls are managed with the Session Initiation Protocol (SIP) standard. An Asterisk server handles the routing of calls. The entire system is integrated into Raytheon's existing C2 application.



Raytheon

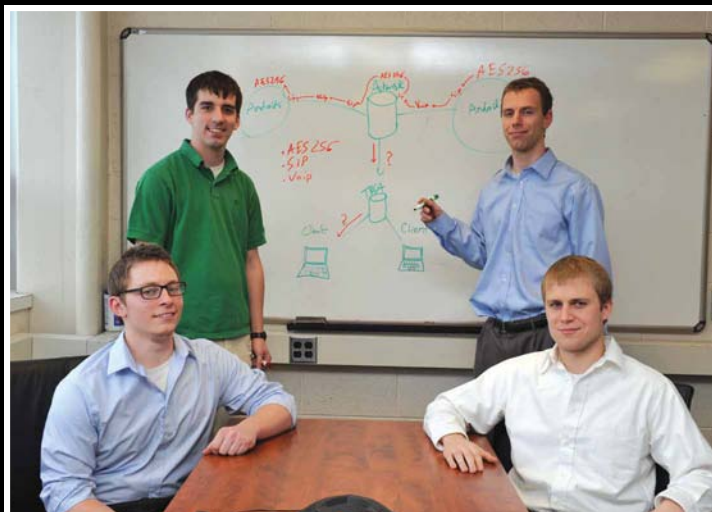

Michigan State University Team Members (left to right)

- Forrest Yockey
Dewitt, Michigan
- Kyle Bartush
Ludington, Michigan
- Benjamin Katt
Concord, California
- Calvin Griggs
Nunica, Michigan

Raytheon Project Sponsors

- Jay Blevins
Fort Wayne, Indiana
- David Emery
Fort Wayne, Indiana
- David Holbrook
Fort Wayne, Indiana
- Jason Hoover
Fort Wayne, Indiana
- David Peter
Fort Wayne, Indiana
- Barry Peterson
Fort Wayne, Indiana
- Daniel Sheline
Fort Wayne, Indiana

Spectrum Health Systems

Web Applications for Healthier Communities

Healthier Communities is a volunteer health services program sponsored by Spectrum Health, the largest health care provider in Western Michigan. Healthier Communities provides medical outreach to the underserved populations.

In 2010, Community Health Workers made 2,599 home visits to 477 participants to collect health data to ensure that they are getting better and staying healthy. Currently, the process of collecting this health data involves the completion of a 23-page paper form, which subsequently must be entered into a computer.

Working with leaders of Healthier Communities and the technical department of Spectrum Health, we have made the entire process digital. Our Web Applications for Healthier Communities system replaces the 23-page paper form with a user friendly iPad web application connected to a database at Spectrum Health.

After logging in, the user simply presses a button to select a participant, open up their file, and start collecting information. They can save, load, and manage participant information with the touch of a finger, without the stack of paper.

One of our application's most appealing features is its look and feel. Even though it is a web application, it appears to the user as a native iPad application.

Our Web Applications for Healthier Communities system is written in C# with JavaScript and is supported by a backend SQL database.

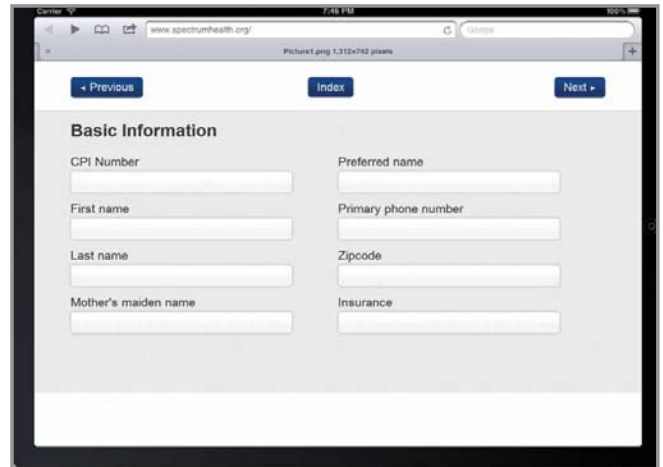

Michigan State University Team Members (left to right)

- Brian Duncan
New Baltimore, Michigan
- Charlie Andrews
Shelby Township, Michigan
- Alper Can
Ankara, Turkey
- Bret Myers
Newberry, Michigan

Spectrum Health Project Sponsors

- Adam Baker
Grand Rapids, Michigan
- Hollie Blagg
Grand Rapids, Michigan
- Jason Joseph
Grand Rapids, Michigan
- Ed Koller
Grand Rapids, Michigan
- Jeremy Meller
Grand Rapids, Michigan
- Patrick O'Hare
Grand Rapids, Michigan
- Sergey Stoma
Grand Rapids, Michigan
- Seth Wentland
Grand Rapids, Michigan

TechSmith

Mobile Smart Video Player

TechSmith is the world leader in screen recording software with millions of users creating informational and educational content. Their content creation products generate valuable metadata that can enhance the viewing experience.

Our Mobile Smart Video Player is an iPhone/iPad application that makes use of this metadata, extending the functionality of TechSmith's Camtasia Studio screen-capture editing software to a mobile environment. It learns what video content is most relevant by sampling each user's tags and by displaying the optimal content to all users.

While watching a screen-capture movie using the Mobile Smart Video Player, a user can gesture to add a bookmark, an on-screen comment about the content, or a SmartFocus zooming or panning point.

Every user-generated tag is added to a database to which tags from users worldwide are constantly being added. The most commonly-placed tags are pulled from this crowd-sourced collection onto all users' iPhones and iPads. Each individual user has the option of viewing their own data alone or the most popular crowd-sourced data from around the world.

Our Mobile Smart Video Player is written in Objective-C. Video content comes from Camtasia Studio. The XML metadata is parsed using Google libraries and is stored in a Microsoft SQL Server database. Our player communicates with the server via the RESTful Open Data Protocol.

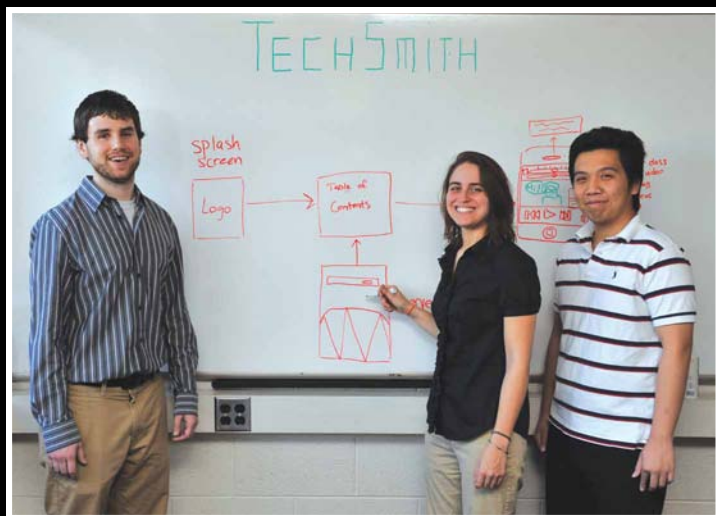

Michigan State University Team Members (left to right)

Scott Klum
Grand Rapids, Michigan

Meryl Dara Mabin
Rockford, Michigan

Yue Lu
Chaozhou, Guangdong, China

TechSmith Project Sponsors

Dean Craven
Okemos, Michigan

Ryan Eash
Okemos, Michigan

Bill Hamilton
Okemos, Michigan

Dave McCollom
Okemos, Michigan

Matt Mercieca
Okemos, Michigan

Mike Simons
Okemos, Michigan

Urban Science Infographics Generator

Urban Science serves the automotive industry by improving the sales and services of its customers using comprehensive data driven analysis of key performance indicators. The results produce higher sales and better services at lower costs.

Our Infographics Generator provides an innovative way to visualize these key performance indicators, helping teams track effectiveness in their primary market areas. Our visualizations serve as a bridge, transporting users from a confusing table of numbers to a vibrant display of relevant information.

The key performance indicators are divided into three main categories: sales, lead management and service. Each category represents a major slice of business. Our drill down display provides a more in-depth explanation of the information shown on the infographic.

An infographic element, a subsection of an entire infographic, can be selected to display a trend chart covering the last six months of data along with a more detailed description of that element.

Our Infographics Generator is a web application designed for use on the iPad. Our web application supports typical touch gestures such as swipe gestures that one would expect on a tablet, thereby giving users the feel of a native application.

Our Infographics Generator is written using HTML5 and JavaScript. Data for the infographics generator is stored using a SQL Server 2008 database then sent in JSON format to the iPad's local storage for fast retrieval.



URBAN SCIENCE



Michigan State University
Team Members (left to right)

- Lok Cheung
Hong Kong, China
- Kevin Shreve
Brighton, Michigan
- Peter Chen
Taipei, Taiwan
- Louis Bodnar
Livonia, Michigan

Urban Science
Project Sponsors

- Matt Bejin
Detroit, Michigan
- Greg Davidson
Detroit, Michigan
- Ryan Hespenheide
Detroit, Michigan
- Shannon Muldowney
Detroit, Michigan

Computer Science and Engineering

Design Day Awards

CSE 498, Collaborative Design, is the senior capstone course for students majoring in computer science. Teams of students design, develop, and deliver a significant software system for corporate clients. The CSE capstone teams compete for four prestigious awards. The winners are selected on Design Day by a panel of distinguished judges.

Auto-Owners Exposition Award



CSE 498 capstone teams present their projects on Design Day in a variety of ways. Teams create and set up an exhibit where they demonstrate their software systems and answer questions from Design Day attendees. Each team plays their project videos and answers questions for a panel of judges.

The CSE capstone team with the best overall Design Day performance is honored with the Auto-Owners Exposition Award, which is sponsored by Auto-Owners Insurance Company of Lansing, Michigan.

Team Spectrum Health
Log Monitoring Compliance



William D. Seeger, Wayne Stiles, Collin Lotus, Kathryn Bonnen
Presented by Bob Buchanan and Jim Schumacher of Auto-Owners

Chrysler Praxis Award



One of the hallmarks of CSE 498 capstone projects is that of praxis, the process of putting theoretical knowledge into practice. Teams apply a wide variety of information technologies to produce solutions to complex problems in areas such as business, engineering, computing, and science.

The CSE capstone team that engineers the software system that is the most technically challenging is recognized with the Chrysler Praxis Award, which is sponsored by Chrysler LLC of Auburn Hills, Michigan.

Team Motorola Mobility
Synchronized Program Content Delivery



Paul J. Detkowski, Tareq Musleh, Timothy Belcher
Presented by Karen Wrobel of Chrysler

Design Day Judges

Ryan Abbott
Loudpixel and Science Exchange

Greg Davidson
Urban Science

Mike Drazan
Toro

Rich Enbody
Michigan State University

Adam Haas
Ford

Louise Hemond-Wilson
IBM

Vandy Johnson
Consultant

Kevin Ohl
Michigan State University

Jim Schumacher
Auto-Owners Insurance

Marty Strickler
Rose Packing Company

Karen Wrobel
Chrysler

TechSmith Screencast Award



Each CSE 498 capstone team produces a video that describes and demonstrates their software product. Starting with a storyboard and a script, teams use Camtasia Studio to synthesize screen recordings, video, audio and other multimedia to produce their project videos.

And the TechSmith Screencast Award goes to...the CSE capstone team with the best project video. The award is sponsored by the creators of Camtasia Studio, TechSmith of Okemos, Michigan.

Team GE Aviation
NextGen Aircraft Taxi Assistance



Johnathan Richter, Jacob Walker, Jason Cepela, Mitchell Thelen
Presented by Dean Craven of TechSmith

Urban Science Sigma Award



The CSE 498 experience represents the capstone of the educational career of each computer science major. An intense semester of teamwork produces impressive deliverables that include a formal technical specification, software, documentation, user manuals, a video, a team web site, and Design Day participation. The resulting sum, the capstone experience, is much greater than the parts.

The capstone team that delivers the best overall capstone experience is recognized with the Urban Science Sigma Award, which is sponsored by Urban Science of Detroit, Michigan.

Team Ford
Ford Qwikboard



William S. White Jr., Danh Tran, Jin Hou, Luke Davis
Presented by Greg Davidson and Matt Bejin of Urban Science

Auto-Owners Insurance

Founded and based in Mid-Michigan since 1916
Ranked Fortune 500 since 2002

Proud Sponsors of
The MSU College of Engineering
Design Day 2012

Employer to some of MSU'S FINEST



WWW.AUTO-OWNERS.COM • LIFE • HOME • CAR • BUSINESS



ECE101 INTRODUCTION TO ELECTRICAL AND COMPUTER ENGINEERING FINAL PROJECTS

Instructor: Dean M. Aslam

Lab Instructors: He-Chuan Cheng, Mostafa Alfatlawi, Atef Abu-Ageel

ECE 101

9:30 a.m.–Noon
Second Floor
Concourse

PROBLEM STATEMENT

ECE 101 is an elective course introducing freshman students to Electrical and Computer Engineering through a series of innovative hands-on laboratory experiments linked to new research and teaching areas. These experiments relate to (a) computer switches, (b) C programming of robots based on MSP430 microcontrollers and NXT LEGO controllers, (c) pH measurement using NXT sensors, (d) maple-seed robotic fliers (MRF) with on board electronics, (e) location of bio-molecules using RFID, (f) renewable energy resources using windmill and solar cells, and (g) nanotechnology study using a LEGO gear-train.



Teams and Members

Team 1:

Non-Traditional Windmill

Team members:

Marcel K. Cochran,
Alex J. Repo,
Eric R. Watson

Description: A non-traditional windmill made using the Objet 3D printer to power a LEGO car.

Team 3:

Maple-seed Robotic Flier (MRF)

Team Members:

Jonathan P. Gardocki,
Justin P. Roe

Description: Maple-seed Robotic Flier (MRF) fabricated using the Objet 3D printer with onboard LEDs and sensors.

Team 4: RFID Sensor – Distance Measurement

Team Members:

Brandon T. Fortier,
Zachary A. Jaghory,
Adam W. Polack

Description: Distance measuring of a curved-line using NXT Robot and RFID sensor.

Team5:

LED Organ

Team Members:

Trevor J. Dirheimer,
Mitchell J. Johnson,
Matthew C. Rasmussen,
Jacob S. Sclater

Description: Detection of different music note frequencies using LEDs.

Team 6

LED Based Solar Cell

Team Members:

Steven J. Brickel,
Marcel D. Daniels-Rich,
Emily E. Seal

Description: A solar cell will be used to power a microcontroller that will remotely control a car using Bluetooth technology.

Team 7

NXT color tracker using light sensor

Team Members:

Patrick M. Kurtz,
Nickolas C. Aguayo,
Erik L. Syvertsen,
Michael F. Latimer

Description: NXT Robot programmed to accurately follow multiple colored lines using light sensor.

Team 8

Musical Floppy Drive

Team Members:

Annalin S. Davis,
Carlisha L. Elam,
Allison M. Korte

Description: Programming of a floppy drive head reader to move at certain frequencies to create a series of combined sounds to make a song.

Team 9

Motion/Color sensor

Team Members:

Joel M. Rubeck, Mario T. Esho, Li He

Description: Programming of NXT Robot to detect colors and perform different actions according to the detected color.

Team 10

Controlled Power Management System

Team Members:

David J. Hill,
Joshua J. Marok,
Robert J. Salton

Description: Storing the power generated by a windmill into a capacitor; the charging process mechanism is controlled by a relay.



DESIGN AND CHARACTERIZATION OF A CMOS 8-BIT MICROPROCESSOR DATA PATH

Instructor: Ms. Shannon Demlow
TA Staff: Haitao Li

PROBLEM STATEMENT

Students in ECE 410 were challenged to design the schematic and physical layout of an 8-bit microprocessor data path, including an Arithmetic Logic Unit (ALU), a barrel shifter, and a register file, using CMOS circuitry and Cadence VLSI design tools. The resulting microprocessor datapath projects will be judged on their ability to satisfy several competing goals:

- Instruction execution speed
- Minimization of total area
- Number of operations
- Technical difficulty of operation set

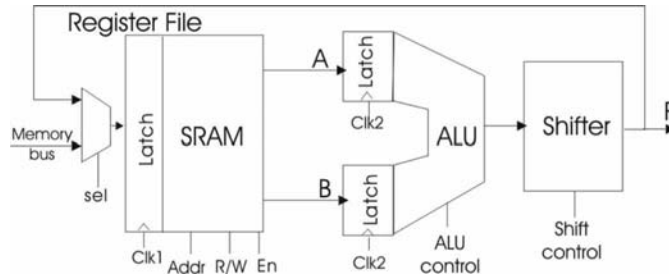

Teams and Members

Team 1	Team 2	Team 3	Team 4	Team 5	Team 6
Team Members: Shaun Eisenmenger Lyle Jackson Kyle Pulis	Team Members: Justin Bohr Nathan Kesto Bin Tian	Team Members: Eric Bell James Hunter Daniel Perez	Team Members: Xie He Tabula Mbala-Nkanga Peng Xie Jacob Zells	Team Members: Derek Brower Alex Koschmann Michael Lazar	Team Members: Austin Fletcher Ryan Popa Yan Sidronio



Intel Outstanding Project Award

The Intel Outstanding Project Award (\$300) will be awarded to the team that produces the best overall project, as judged by a panel of experts from industry and academia. The faculty and students of Electrical and Computer Engineering are very grateful to Intel for the generous sponsorship of this award.



ELECTRICAL AND COMPUTER ENGINEERING PROJECTS

PRESENTATION SCHEDULE — Lake Huron Room

Course Coordinator: Professor Michael Shanblatt

Faculty Advisors: Professors Professors Deller, Dong, Hogan, Oweiss, Radha, Ren, Tan

ECE 480

**8:00 a.m. – Noon
Third Floor
Lake Huron Room**

Time	Project Sponsor(s)	Sponsor Representative(s)	Faculty Facilitator(s)	Project Title
8:00 ECE 480	Dow Chemical and Michigan State University	E. Goodman	T. Hogan	Tanzania Humanitarian Project: GSM Data Link for Satellite Control
8:25 ECE 480	Texas Instruments	P. Semig	J. Ren	Wireless Sensing System for Intelligent Concrete Curing
8:50 ECE 480	Air Force Research Laboratory	D. Lemaster	K. Oweiss	Android Enabled Programmable Camera Positioning System
9:15 ECE 480	Air Force Research Laboratory	C. Taylor	J. Deller	A Minimal Size, Weight and Power System for Key Length Value Metadata Generation for Remotely Piloted Vehicle Sensors
9:40–10:00 Break				
10:00 ECE 480	Lincoln Laboratory	B. Perry	H. Radha	Interactive Radar Demonstration for Children
10:25 ECE 480	Michigan State University Zoology Department	K. Holekamp	X. Tan	Animatronic Hyena for Field Research in Kenya
10:50 ECE 480	XG Sciences	J. Narendra	L. Dong	Battery Cell Testing Chamber, an Accurate Control System
11:15 ECE 480	Battelle	C. Ball	J. Ren	Remote Control and Monitoring of Sensors by Android Smartphone
11:40 ECE 480	ArcelorMittal	T. Whittaker	T. Hogan	Blast Furnace Moisture Measurement

ECE 480 Senior Capstone Design

ECE 480 is required of all electrical engineering or computer engineering majors at MSU.

It prepares students for the workplace, or for graduate school, including:

- Putting into practice the technical skills learned in the classroom, on industrially sponsored team projects, under faculty guidance, doing open-ended design, giving them experience in teamwork, project management, product life cycle management, legal, intellectual property and accommodation issues, and in entrepreneurship.
- Polishing their communication skills – individual and team – on proposals, reports, resumes, evaluations, posters, web pages, and oral presentations.
- Requiring each student to complete four individual hardware/software laboratory assignments.

Team sponsors are local and national, including Texas Instruments, Dow Chemical Company, Air Force Research Laboratory, MIT Lincoln Laboratory, MSU Dept. of Zoology, XG Sciences, ArcelorMittal, and Battelle Laboratories

Tanzania Humanitarian Project: GSM Data Link for Satellite Control

Our team, in cooperation with the Telecommunications department, has designed a remote access Internet system that we will also be installing in Mto wa Mbu, Tanzania. MSU has been involved in a development project bringing computers and Internet access to schools in Tanzania for the past four years and has contributed greatly to the quality of education opportunities in Africa. The major issue that our project is to address is Internet availability and power management.

Our system is designed to supply Internet access to multiple rural schools in Tanzania. These schools have various limitations which include power restrictions due to solar-powered batteries. To overcome these limitations, we have created a system that can allow for on-demand Internet access. By using the Global System for Mobile Communications (GSM) standard we can reliably signal the remote satellite Internet system to power on.

Included within our system is a microcontroller, a GSM module, a battery monitoring system, and an Internet monitoring system. Together these components actively provide an Internet on-demand system while also monitoring the health of components within the system. These systems are vital to improving the longevity of the Internet system currently in operation in Mto wa Mbu.

<http://www.egr.msu.edu/classes/ece480/goodman/spring12/group01>



D. Newell
Electrical Eng

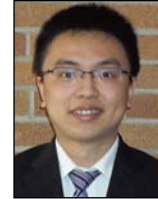

Q. Gou
Electrical Eng



K. Jordan
Electrical Eng



I. Gallardo
Computer Eng



J. Pawloski
Computer Eng



MICHIGAN STATE
UNIVERSITY

Study Abroad



Prof. Goodman

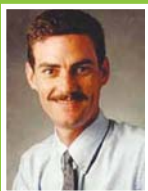

Dr. Tim Hogan

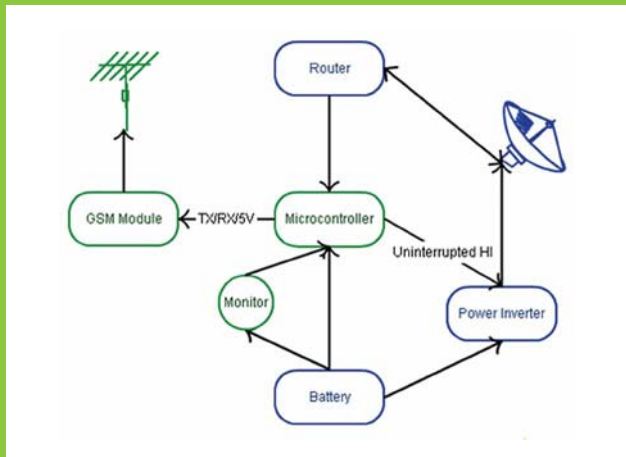

Project Sponsor
Michigan State
University
Dow Chemical

**Sponsor
Representative**
Dr. Erik Goodman

**Faculty
Facilitator**
Dr. Tim Hogan

**Team Members
& Non-Technical
Roles**

Drew Newell
Manager

Jeffrey Pawloski
Webmaster

Kenneth Jordan
Documentation Prep

Ivan Gallardo
Presentation Prep

Qilong Gou
Lab Coordinator

Texas Instruments

Wireless Sensing System for Intelligent Concrete Curing

The concrete curing process is a complicated process that involves many variables. Improperly cured concrete can be exceptionally fragile. Our team has removed the uncertainty of the process by developing an embedded sensor system that reports the temperature and moisture content of the wet concrete. These two parameters provide the user with the data necessary to make a more precise decision on when the concrete has cured.

The system provides a demonstration of Texas Instrument’s MAVRK prototyping platform. The sensor and μ MAVRK modules create a single, compact unit that can be placed directly in the concrete. Our sensor module contains the temperature and moisture sensors along with the necessary signal amplification and conditioning. These signals are sent to the μ MAVRK module where they are converted to digital signals and sent to the MAVRK motherboard via RF transmission. The MAVRK routes the data to a PC which displays the data with a user-friendly GUI.

The combination of temperature and moisture sensing with wireless data transmission is a solution which is currently unavailable for purchase. Implementation of this system can save the user time and money by preventing weak, improperly cured concrete or allowing the project to move forward if curing occurs quickly.

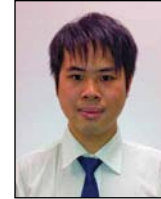

C.Y. Lim
Electrical Eng



J. Sangregario
Electrical Eng



K. Gladstone
Electrical Eng

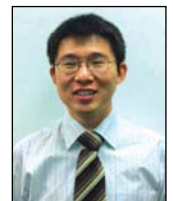

S. Li
Electrical Eng

<http://www.egr.msu.edu/classes/ece480/capstone/spring12/group02/>



Mr. Semig



Prof. Ren

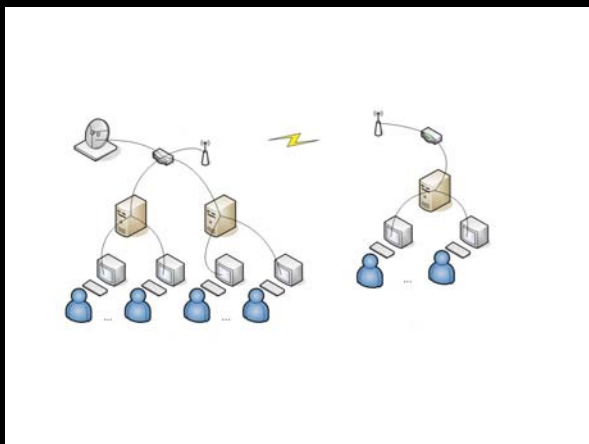

Project Sponsor
Texas Instruments

Sponsor Representative
Mr. Pete Semig

Faculty Facilitator
Dr. Jian Ren

Team Members & Non-Technical Roles

Chai Yong Lim
Manager

Stephen Yanqing Li
Webmaster

Jon Sangregario
Documentation Prep

Kevin Gladstone
Presentation Prep

Air Force Research Laboratory: Android Enabled Programmable Camera Positioning System

Design Team 3 was tasked with developing an Android enabled GPS-based camera positioning system for the Air Force Research Laboratory (AFRL). The AFRL will use this system to automate the positioning of an infrared camera to perform field testing of infrared imaging technology and processing algorithms. Automated motorized mounts similar to this are already used for surveillance cameras and telescope systems; however these systems typically do not have a built-in GPS receiver and require that data be entered manually. This project was designed to produce a low-cost, off-the-shelf solution by utilizing the sensory and computation capabilities of an Android smartphone.

This project entailed constructing the motorized camera mount for a 19 pound infrared camera that is capable of being controlled by an Android smartphone. We also developed software for the phone's location awareness and target acquisition as well as a camera control program to be run on an external laptop. The developed system is able to point with high accuracy at any targeted GPS coordinate (latitude, longitude, and altitude) on a pre-programmed script. In order to do this, the system detects its own location and orientation and then calculates the necessary orientation so that the infrared camera focuses on its target location by issuing controls to the motors on the mount. The phone then signals the camera to capture an image and takes one itself as context imagery.

<http://www.egr.msu.edu/classes/ece480/capstone/spring12/group03/index.html>



J. Iamurri
Computer Eng



A. Fletcher
Computer Eng



C. Sigler
Computer Eng



Y. Sidronio
Computer Eng



R. Popa
Computer Eng



Dr. Lemaster



Dr. Oweiss



Project Sponsor
Air Force Research Laboratory

Sponsor Representative
Dr. Daniel Lemaster

Faculty Facilitator
Dr. Karim Oweiss

Team Members & Non-Technical Roles

Austin Fletcher
Manager

Ryan Popa
Webmaster

Chris Sigler
Documentation Prep

Yan Sidronio
Presentation Prep

Jeremy Iamurri
Lab Coordinator

Air Force Research Laboratory: A Minimal Size, Weight, and Power System for Key Length Value Metadata Generation for Remotely Piloted Vehicle Sensors

Our project is focused on improving the functionality of an RPV designed to fly over forest fires and record video. Current technology does not enable the video, attitude, and location data to be synchronized. Also, the orientation and location data are not associated with the sensor gathering the video, but instead with the RPV itself. The goal of our project is to resolve these problems by attaching an enclosure containing sensors and a computer-on-module (COM) to the RPV's camera.

The enclosure contains a GPS unit, an Inertial Measurement Unit (IMU), and a COM. The system collects and outputs the location and orientation data of the camera. The location and orientation data is output in a standard format and synchronized with the video frames. The team has developed the system to be compact, lightweight, and low power, because all of these aspects are important for RPVs.

<http://www.egr.msu.edu/classes/ece480/capstone/spring12/group04/>



I. Hoffman
Electrical Eng



C. Fox
Electrical Eng



D. Toussaint
Electrical Eng



J. Jonckheere
Computer Eng



P. Xu
Computer Eng



Dr. Taylor



Dr. Deller

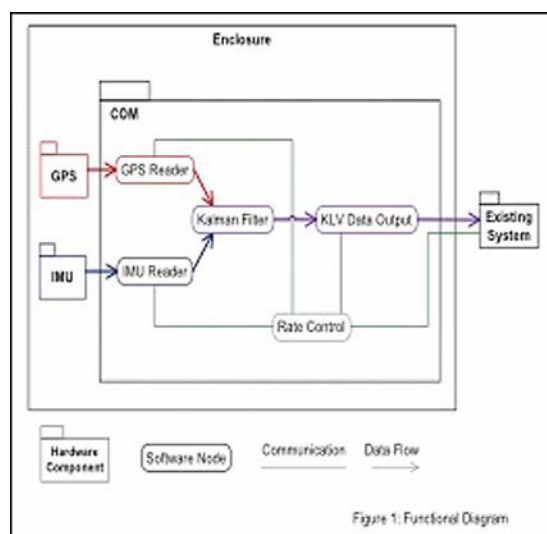

Project Sponsors
Air Force Research Laboratory

Sponsor Representative
Dr. Clark Taylor

Faculty Facilitator
Dr. John Deller

Team Members & Non-Technical Roles

Dan Toussaint
Manager

Isaac Hoffman
Webmaster

Carrie Fox
Documentation Prep

Peng Xu
Presentation Prep

Jared Jonckheere
Lab Coordinator

Lincoln Laboratory: Interactive Radar Demonstration for Children

Massachusetts Institute of Technology Lincoln Laboratory (MITLL) developed a kit to demonstrate radar system principles utilizing affordable, off-the-shelf parts and a simple, easy-to-understand design. MITLL's kit is designed for use with a laptop as the processing unit. To extract the desired information from the radar output signal, it must undergo a user-facilitated processing sequence, and the data thus cannot be displayed in real time. Our project goal is to automate signal interpretation and to display target range and speed in real time. The radar screen appeals to children by generating interactive, visually-stimulating graphics.

<http://www.egr.msu.edu/classes/ece480/capstone/spring12/group05/index.html>



A. Renton
Elec./Comp. Eng



S. Hughey
Electrical Eng



N. Syuhada Zakaria
Electrical Eng



A. Myrick
Electrical Eng



Dr. Perry



Dr. Radha



Project Sponsor
MIT Lincoln Lab

Sponsor Representative
Dr. Bradley Perry

Faculty Facilitator
Dr. Hayder Radha

Team Members & Non-Technical Roles

Andrew Renton
Manager

Stephen Hughey
Webmaster

Andrew Myrick
Documentation Prep

Nur Syuhada Zakaria
Presentation Prep

Robotic Hyena Project :

Animatronic Hyena for Field Research in Kenya

Our design team is working with Dr. Kay Holekamp of the Michigan State University Zoology Department to construct a robotic hyena that imitates the key characteristics of hyena body language. Currently, Dr. Holekamp uses a static model hyena to research wild hyenas' initial responses to newcomers in their social hierarchy.

The goal of this project is to incorporate head, ear, and tail movement into the current hyena model, and allow wireless control of these movements from a distance. Hyenas use body language as a key indicator of their tendencies toward other hyenas – for instance, a hyena with its ears forward, tail up, and head forward is displaying an aggressive stance toward another hyena. Our robot is able to mimic hyena body language so that Dr. Holekamp may incite more realistic responses from hyenas in the wild.

The robot is controlled using an intuitive graphical user interface on a laptop computer, which sends serial communications wirelessly using the ZigBee protocol to an on-board Arduino processor. This processor controls the movement of the servo motors, which dictate the outward behavior of the robot. Head and ear movement are controlled by independent servo-and-gear systems, while the tail is controlled by varying wire tension within the flexible tail structure.

<http://www.egr.msu.edu/classes/ece480/capstone/spring12/group06>



R. Schwarz
Electrical Eng



K. Dabiran
Electrical Eng



E. Mitchell
Electrical Eng



L. Voskov
Electrical Eng



P. Zanotti
Electrical Eng



Dr. Holekamp

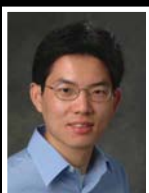

Dr. Tan

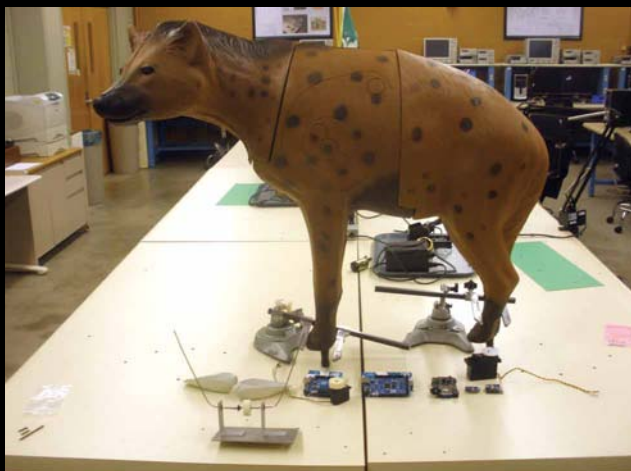

Project Sponsor
*Michigan State University
Zoology Department*

Sponsor Representative
Dr. Kay Holekamp

Faculty Facilitator
Dr. Xiaobo Tan

Team Members & Non-Technical Roles

Ross Schwarz
Manager

Eric Mitchell
Webmaster

Kasra Dabiran
Documentation Prep

Leon Voskov
Presentation Prep

Phil Zanotti
Lab Coordinator

XG Sciences: Battery Cell Testing Chamber, an Accurate Control System

When running tests on battery cells, temperature plays a large role in the results. Our design team was tasked by XG Sciences with modifying an existing environmental chamber to accurately control temperature for such tests.

Our final design is based on two control principles, PID (proportional, integral, derivative) control and Pulse Width Modulation (PWM). By designing these two controllers we were able to achieve a high level of accuracy, as well as a highly stable temperature. The chamber can operate over a wide range of temperatures from -40°C to 85°C .

Our final design also incorporated an alarm system that triggers if the temperature deviates too far from its set point. All of these features were created with an external microcontroller development board. This allowed us to design a new control system without the need to rebuild the entire chamber.

<http://www.egr.msu.edu/classes/ece480/capstone/spring12/group07/ECE480/Index.html>



A. Behbehani
Electrical Eng



B. Pasbjerg
Electrical Eng



C. Qu
Electrical Eng



M. Marcantonio
Electrical Eng



Mr. Narendra



Prof. Dong

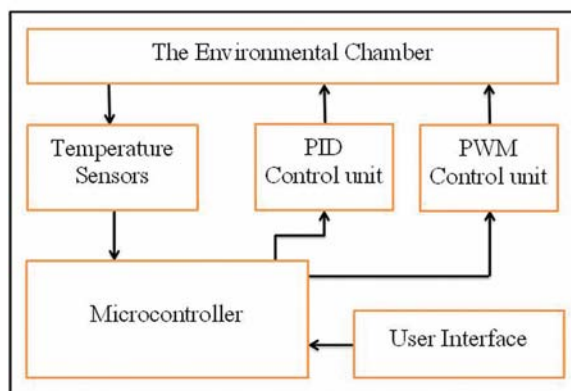

Project Sponsor
XG Sciences Inc.

Sponsor Representative
Mr. Jeffri Narendra

Faculty Facilitator
Dr. Lixin Dong

Team Members & Non-Technical Roles

Matthew Marcantonio
Manager

Chengeng Qu
Webmaster

Brad Pasbjerg
Documentation Prep

Ali Behbehani
Presentation Prep

Battelle: Remote Control and Monitoring of Sensors by Android Smartphone

Battelle Laboratories, a non-profit research and development enterprise, has sponsored Team 8 to find and develop a method of remotely controlling and monitoring four sensors using an Android smart-phone. This method can potentially be used in combat situations for detecting hazardous chemicals on the battlefield. In such an environment, existing wireless communication networks may be unavailable, so the phone must establish its own independent connection with the sensors. In addition, portability, ease of use, and reliability are crucial to the success of the design. Team 8 has designed for these criteria and developed a method for communication, creating an Android application that runs on the phone, enabling the user to monitor the sensors through a simple graphical user interface (GUI). The phone is connected via Universal Serial Bus (USB) to a development board, which is connected to a MiWi radio frequency transmitter that wirelessly connects to multiple sensors. As the sensors collect new data, they send their findings over the MiWi network to the phone, which then updates the GUI.

<http://www.egr.msu.edu/classes/ece480/capstone/spring12/group08/index.html>

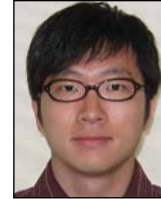

D. Ha
Computer Eng



M. Zastrow
Computer Eng



M. Allon
Computer Eng



P. Krutty
Computer Eng

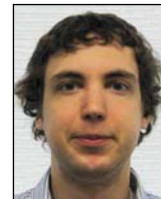

S. Hilton
Elec./Comp. Eng



Dr. Ball

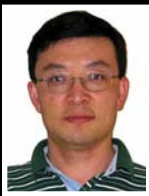

Dr. Ren

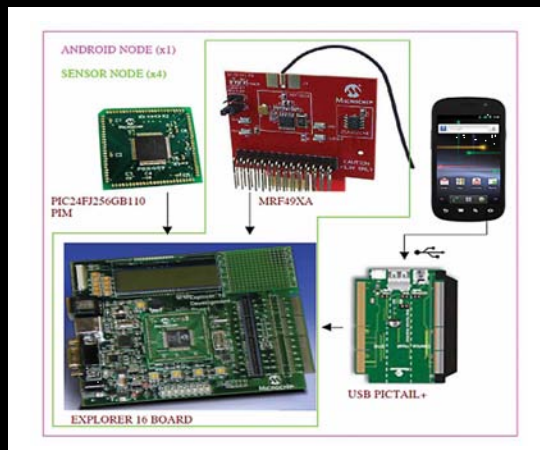

Project Sponsor
Battelle

Sponsor Representative
Dr. Christopher Ball

Faculty Facilitator
Dr. Jian Ren

Team Members & Non-Technical Roles

Stephen Hilton
Manager

Micah Zastrow
Webmaster

Michael Allon
Documentation Prep

Paul Krutty
Presentation Prep

Donghun Ha
Lab Coordinator

ArcelorMittal: Blast Furnace Moisture Measurement Device

The purpose of this project is to accurately measure the moisture content in a blast furnace pipe. Measuring six feet in diameter, the pipe travels from the blast furnace to boilers at a power station. Burning the exhaust gas from the blast furnace is an inexpensive alternative to natural gas. However, the gas contains moisture which corrodes the inside of the pipe. Understanding the moisture content enables proactive measures that can be taken to reduce the moisture content which prolongs the life of the pipe. The theoretical way of measuring the moisture in the pipe was non-intrusive using an ultrasonic device but was found to be inaccurate and expensive. Instead, the team was allowed to go intrusive and has designed and created a device that measures moisture accurately.

The device is composed of a capacitive sensor element which works in sync with a microcontroller to provide interval data measurements of the moisture or on command. Since the device can be inserted into an enclosure with pipe thread, it can be attached to any of the six intake lines. With this versatility, it doesn't require the user to purchase six different devices unless simultaneous measuring is requested.

More than 95% of the unit resides outside of the pipe and communicates accurate data measurements of both temperature and humidity to the user. With this data, the end user can then adjust the gas levels in the pipe appropriately to reduce condensation.

<http://www.egr.msu.edu/classes/ece480/capstone/spring12/group09>



J. Zells
Computer Eng



J. Stoller
Computer Eng



M. Voog
Electrical Eng



Y. Liang
Electrical Eng



Mr. Whittaker



Dr. Hogan

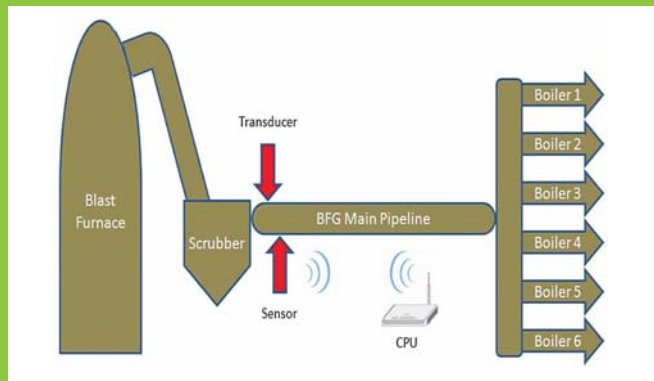

Project Sponsor
ArcelorMittal
Corporation

Sponsor Representative
Mr. Thomas
Whittaker

Faculty Facilitator
Dr. Tim Hogan

Team Members & Non-Technical Roles

Jacob Zells
Manager

Jeff Stoller
Webmaster

Yuan Liang
Documentation Prep

Matt Voog
Presentation Prep



**TO SEE CHEMISTRY THROUGH THE EYES OF
HUMANITY IS TO SEE THE PROMISE OF A BETTER
FUTURE.** That's the power of the Human 

Element. The Dow Chemical Company proudly supports MSU College of Engineering's Design Day and the hope for the future it represents.

Design Day Awards:

MICHIGAN STATE UNIVERSITY COLLEGE OF ENGINEERING

Electrical & Computer Engineering Prism VentureWorks Prize & Winners, Fall 2011

The Prism VentureWorks Prizes (\$1,500, \$1,000, and \$500, respectively) are awarded each semester to the most outstanding teams in the Electrical and Computer Engineering Senior Capstone Design Course, as judged by a panel of engineers from industry. A team with members from both ECE and another engineering major (mechanical engineering, for example) is also eligible, if the team's project is administered through ECE 480. The prizes are sponsored by Prism VentureWorks, a Boston-based venture capital firm, and Mr. William Seifert, an ECE alumnus, who is a partner in that firm. The faculty and students of Electrical and Computer Engineering are very grateful for this generous support.

First Place Award for Cypress Semiconductor: Arduino Friendly PSoC Shield



LEFT TO RIGHT:
Cecilia Acosta, Aaron Thompson, Matt Durak, Nathan Ward, Brett Donlon

Second Place Award for Texas Instruments: Wireless Sensing System for Intelligent Concrete Curing

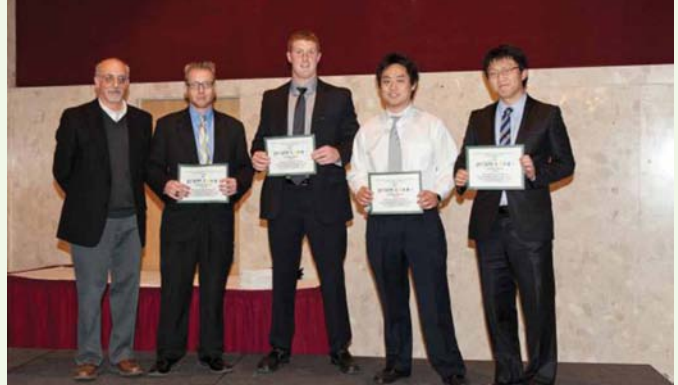

LEFT TO RIGHT:
Kyle Schultz, Jordan Bennett, Kevin Yeh, Min Jae Lee

Third Place Award for RCPD: iDOCENT Phase II: Indoor Digital Orientation Communication and Enabling Navigation



LEFT TO RIGHT:
Vadim Kim, Shreyas Thiagarajasubramanian, Adam Partio, Kirk Guotova

ECE 410 Intel Outstanding Project Award begins this year!

The Intel Outstanding Project Award (\$300) will be awarded to the ECE 410 design team that produces the best overall project, as judged by a panel of experts from industry and academia. The faculty and students of Electrical and Computer Engineering are very grateful to Intel for the generous sponsorship of this award.



Design Day Awards:

MICHIGAN STATE UNIVERSITY COLLEGE OF ENGINEERING

Electrical & Computer Engineering Capstone Poster Award & Winner, Fall 2011

Each team in ECE 480, Senior Capstone Design, exhibits a poster and the items they have built during the semester and answers questions, from 8:00am-noon in the Union Ballroom. Judging of the best poster/demo is done by the groups of high school students participating in Design Days, based on their appeal and effectiveness in communicating the project goals and achievements. A prize of \$1000 is awarded to the most outstanding team.



First Place Award for Cypress Semiconductor: Arduino Friendly PSoC Shield

LEFT TO RIGHT:

Dean Satish Udpa, Nathan Ward, Brett Donlon, Cecillia Acosta, Matt Durak, Aaron Thompson, and Prof. Michael Shanblatt

aeemsu.com

audio **AEE** enthusiasts and engineers



Design Day:
April 27th, 2012
8 a.m. until 1 p.m.

Second Floor Concourse:
Come hear and see all that we have done this semester.

OUR HISTORY:

Fall of 2006 a small group of engineers founding Audio Enthusiasts and Engineers, an organization open to all Michigan State University students. The first semester AEE designed and built their first masterpiece 'Revolution Audio', a stereo system engineered to produce true stereo sound regardless of which direction the listener is facing. AEE has become one of the most active student organizations in the College of Engineering. Its members are devoted to understanding audio concepts, as well as finding inventive ways to implement this knowledge. aeemsu@gmail.com



THEREMIN

Building a Theremin has shown how specialized oscillating circuits using the heterodyning principal can be used to create some very unique audio devices.



GUITAR PEDALS

Along with our Tube Amps a team built an assortment of Guitar Pedals. Members of this team learned research skills and how to use schematics and a soldering iron.



MOLDED EARBUDS

This team has been working to design and build in-ear headphones with mics on the outside to capture and listen to sound exactly as someone would live. Our members have learned valuable skills in research and development.



TUBE AMPS

This semester the Tube Amp Team built a variety of guitar amplifiers. Those involved in the Tube Amp Team quickly become knowledgeable about reading schematics, component layout, grounding and especially soldering.



Carry your Spartan Pride!

Take MSUFCU With You

When you graduate, you don't have to close your account. Wherever your new career opportunities take you—take MSUFCU with you!

Shared Branching & Service Centers are a network of credit union locations where you can access your MSUFCU account for FREE and are available nationwide! Find a location near you at www.cuservicecenter.com.

ComputerLine & Mobile Banking Use ComputerLine, MSUFCU's free online banking to perform over 40 transactions anywhere, anytime as long as you have internet access. Plus, Green on the Go® Mobile Banking provides fast and secure account access anytime, anywhere for FREE* from your internet-compatible mobile phone.

eDeposit allows you to electronically deposit checks or apply them to your loans through ComputerLine. Simply scan your paper checks from home and apply them to your account!

FREE ATMs There are over 100 FREE MSUFCU ATMs in the Greater Lansing area and over 28,000 FREE CO-OP Network ATMs located nationwide where you can access your MSUFCU account, make transfers, and more.

Extended Hours We know you'll be busy once you start working 9 to 5, so we make it easy to get in touch by offering extended hours online and over the phone. Speak with a member service specialist Monday-Friday from 7:00 a.m. to 9:00 p.m. and Saturdays from 9:00 a.m. to 3:00 p.m. Or contact us online via Instant Chat Monday-Friday from 8:00 a.m. to 7:00 p.m. and Saturdays from 9:00 a.m. to 3:00 p.m.



Federally Insured
by the NCUA

(517) 333-2424 • www.msufcu.org • 800-678-4968

*Although MSUFCU does not charge any fees for Green on the Go® mobile banking service, connectivity, access, or usage fees from your wireless provider may still apply.



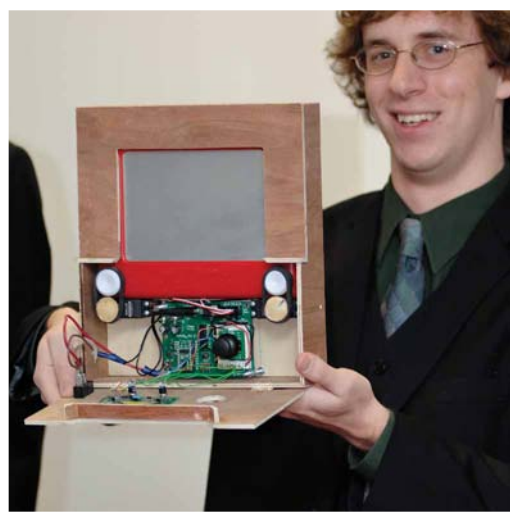
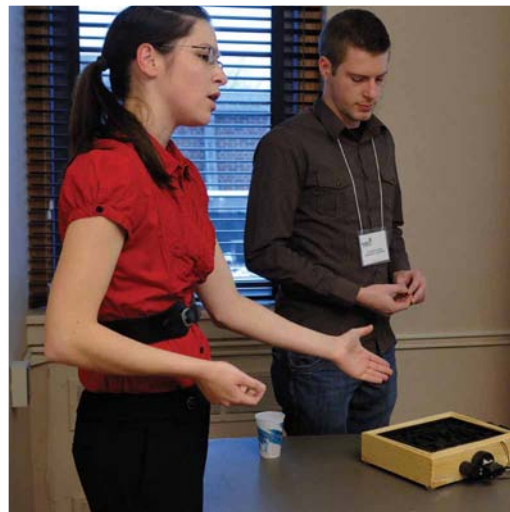
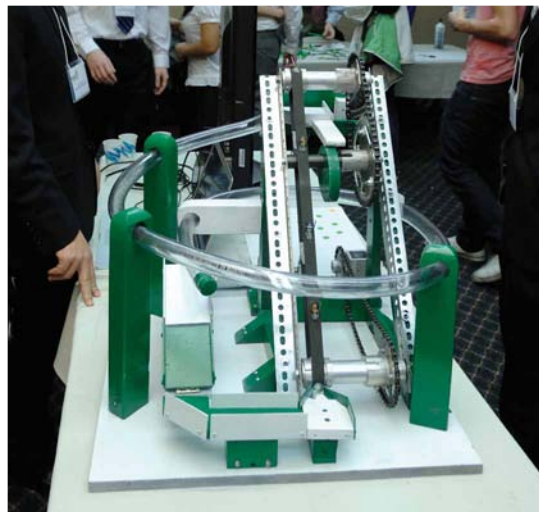

Mechanical Engineering Design Program

Mechanical engineers make the world move and provide the energy to do this. The goal of the mechanical engineering program at MSU is to graduate engineers that are prepared to **Lead, Create, and Innovate** in their professional careers. The MSU Mechanical Engineering Design Program is the key element of the curriculum to achieve this goal. The five required design courses in the program provide the students with eight hands-on team-based design, build, test projects, six written communication experiences, three oral presentation experiences, and three poster presentation experiences. It is the Mechanical Engineering Design Program that distinguishes the ME program nationally and makes it one of the elite programs in the world.

The Mechanical Engineering Design Program would like to thank our Edison judges and their companies for their commitment to our design program.

Asif Nasar, The Boeing Company
Jim Wilde, Beijing West Industries Co. Ltd.
Steve Rohde, Quantum Signal, LLC
Michael N. MacCallum, Brooks Kushman

ME 481 Mechanical Engineering Design Projects

ME481 is required for all mechanical engineering majors at MSU. The course provides students with a team-based capstone design experience:

- Using the technical expertise, communication skills, and teaming methodologies they have learned throughout their mechanical engineering curriculum, along with their creativity, to solve real world problems.
- Collaborating with practicing engineers to address problems sponsored by industry.
- Developing new products or re-designing existing products to reduce costs or enhance reliability.
- Interacting with large, medium-sized, and small companies involved in orthodontic devices, furniture, aerospace structures, automotive parts, consumer electronics, materials recycling, food processing, and machine tools.

Other projects are humanitarian based, in which the students work with individuals who have special challenges.

Project sponsors include American Hydromech, Robert Bosch, LLC, Chrysler LLC, Ford Motor Company, Heartwood School, Lansing Schools K-8 STEM Academy, Louis Padnos Iron & Metal Company, Nexteer Automotive, Peckham, Rennco LLC, Shell Oil Company, The Appropriate Technology Collaborative and Whirlpool Corporation

Design Day Awards:

MICHIGAN STATE COLLEGE OF ENGINEERING

Mechanical Engineering: Thomas Alva Edison Undergraduate Design Award

The Edison Scholars are recognized as the ME 481 Design Team that has produced the most outstanding project. A jury of experts from industry and academia evaluate the final reports, the posters, and the final oral presentations in determining the award winners. Teams operating under ME 481 that include members from other departments and colleges are also eligible for this award. The funding for this award is provided by the Shell Oil Company.



*l-r: Bryan Walega,
Michael Olsztyn,
Brandon Gandy and
Robert Wooten with their
industrial advisor
Mr. Gregory Hortin.*

FALL 2011 ME 481 EDISON UNDERGRADUATE DESIGN AWARDS

Brandon Gandy
Michael Olsztyn,
Bryan Walega
Robert Wooten

ME 481 Oral Presentation Award



The best ME 481 oral presentation as determined by the ME 481 students is recognized with this award.

*l-r: Andrew Binell,
Mathew Lemke,
Justin Freeman,
Zachariah Sprinkle and
Joshua Racalla with their faculty
advisor Prof. Nikolai Priezev.*

FALL 2011 ME 481 ORAL PRESENTATION AWARDS

Andrew Binell
Mathew Lemke
Justin Freeman
Joshua Racalla
Zachariah Sprinkle

ME 481 Outstanding Poster Award



The ME 481 Outstanding Poster Award recognizes the best poster presented by an ME 481 design project team as judged by a team of individuals from industry and academia. Judging is based on both technical content and aesthetic layout.

*l-r: Prof. Clark Radcliffe presenting
the Award to the Design Team:
Nicholas Righetti, John Chancey,
Alexander Danaj, Alexander Tollis
and Theodore Belanger.*

FALL 2011 ME 481 POSTER PRESENTATION AWARD

Theodore Belanger
John Chancey
Alexander Danaj
Nicholas Righetti
Alexander Tollis

Design Day Awards:

MICHIGAN STATE COLLEGE OF ENGINEERING

ME 471 Machine Design Award

The student team members winning the ME 471 competition at Design Day are recognized with the Machine Design Award. The award winners are determined by the course instructors based on team scoring in the competition. The funding for this award is provided by the Shell Oil Company.



l-r: Prof. Ronald Averill presenting the award to the design team: Werner Dahm, Nicholas Schooley, Haley Orr and Andrew Grossman (not shown)

FALL 2011 ME 471 MACHINE DESIGN AWARD

Werner Dahm
Andrew Grossman
Haley Orr
Nicholas Schooley

ME 412 Heat Transfer Laboratory Heat Transfer Design Award

The student team members winning the ME 412 competition at Design Day are recognized by the Heat Transfer Design Award. The award winners are determined by the course instructor based on team scoring in the competition.



FALL 2011 ME 412 HEAT TRANSFER DESIGN AWARD

Andrew Grossman
Zachary Kadykowski
Joshua Ringbloom

l-r: Dr. Laura Genik presenting the award to the design team: Joshua Ringbloom, Zachary Kadykowski and Andrew Grossman (not shown)

ME 456 Best Mechatronic Product Design Award

The integrated design of products and processes that include mechanical and electrical components under intelligent control.



FALL 2011 ME 456 BEST MECHATRONIC PRODUCT DESIGN AWARD

Ian Forney
Katherine Hilton
Nur Joned
Joshua Racalla

l-r: Prof. Clark Radcliffe presenting the award to the Design Team: Ian Forney, Nur Joned, Katherine Hilton, and Joshua Racalla

ME 371 Mechanical Design I Kids' Choice Award

The pre-college students participating in Design Day vote for the most outstanding ME 371 projects. The winning teams are designated as the Kids' Choice Award.



FALL 2011 ME 371 KIDS' CHOICE AWARD

Top Picture
Caitlin Bailey
Benjamin Bosworth
Olukemi Mejabi
Katie Renaud

l-r: Dean Satish Udpa, Caitlin Bailey, Katie Renaud, Benjamin Bosworth, Olukemi Mejabi and Prof. Brian Thompson

Bottom Picture
Ross Dudgeon
Charles Ferriera
Colin Perrault
Brendan Brown

l-r: Dean Satish Udpa, Ross Dudgeon, Charles Ferriera, Colin Perrault, Brendan Brown and Prof. Farhang Pourboghbrat



THRILLS FOR PRE-COLLEGIATES: MECHANISMS THAT FASCINATE, CAPTIVATE, STIMULATE AND ENTICE

INSTRUCTOR: Professor Farhang Pourboghrat

PROBLEM STATEMENT

Teams of students were required to design and manufacture mechanisms that would thrill an audience of pre-collegiate students. The only constraints imposed upon the assignment were that each mechanism must incorporate at least one linkage, one gear set and one cam-follower combination. These engineering marvels will be displayed along with a complementary poster explaining the subtleties of each mechanism, and each device will be demonstrated to the eager audience. Every ME 371 team will be interviewed by the pre-collegiate students who will assign points to each MSU team. Subsequently these points will be tallied and the winning team awarded the Sparty Plaque for creating the most thrilling mechanism. This inspiring plaque was designed and fabricated by students at Holt Junior High School more than a decade ago.

Teams and members

Team 1

Jacob Davenport
Daniel Dokter
Garrett McManaman
Jon Woo

Team 2

Scott Bachor
Ruibo Gong
Ming Mu
Xu Yue

Team 3

Benjamin Dean
Peter Dolce
Andrew Hine
Craig Miller

Team 4

Jennifer Henige
Sarah Kurtz
Carly Patterson
Michael Ryerkerk

Team 5

Riley Chapdelaine
Joel Cosner
Chad Houlihan
Joe Koterba

Team 6

Thomas Dionne
Adam Lang
Tyler Rumler
Austin Tokarski

Team 7

Gustavo Gomes
Ben Oberski
Stephen Sommerlot
Evan Yoder

Team 8

Benjamin Cooper
Steven Cooper
Harrison Cummings
Adam Leenheer

Team 9

Robert Caldwell
Nick Hansen
Yizheng Wang
Yanfeng Wu

Team 10

Matt Bach
Mariah Krebs
Shiva Ramasami
Jason Thelen

Team 11

Steven Gerdeman
Aerin Klump
Mike Marshall
Tianyu Zhao

Team 12

Ben DeWys
Rami Janoudi
Yichu Jin
Jonathan Shapiro

Team 13

Kathleen Fitzsimons
April Oesterle
Eric Rightor
Chris Stanos

Team 14

Alex Benson
Brett Hewitt
Taylor Mantey
Raymond Peterson

Team 15

Andrew Bloch
Dan Dreliazis
Steve Gorney
Gregory Smiecinski



ME 412

8:20 a.m. – Noon
Second Floor
Parlor A



THE HOT WORT CHILLER

INSTRUCTOR: Dr. Laura J. Genik

TA Staff: Vasily Ivanov, Christopher Paul, David Schrock

In the home brew process, hot wort is created (wort is unfermented beer) by boiling the mash with hops and other ingredients to stabilize the mixture and develop flavors while removing proteins. The wort must be cooled into the 70°F range to create an environment for the addition of the yeast to begin the fermentation process. Too high a temperature will kill the yeast. At the higher end of the scale (140°F) bacteria can still survive in the wort that will lead to contamination of the brew. Cooling slowly will give bacteria and other contaminants time to fester in the wort creating off flavors and aromas. The desire is to cool it quickly and add the yeast to begin the fermentation process while maintaining a fresh hops taste.

PROBLEM STATEMENT

The project team is to design, analyze, build, and test a wort chiller. The group will be supplied with a gallon container for the wort, simulated with boiling water. No dilution of the wort can occur and the cooling device must be manufactured by the team. All components of the device will need to fit inside the size constraint. The wort will begin the process at approximately 212°F and must be cooled to 70°F in 15 minutes or less. If the design team is utilizing less than 15 minutes of time for cooling, the team must have a pre-determined stop time. The design team will be penalized in competition if the wort is below the target temperature.

TIME

8:20 a.m.

8:40 a.m.

8:40 a.m.

9:00 a.m.

9:00 a.m.

9:20 a.m.

9:20 a.m.

9:40 a.m.

9:40 a.m.

10:00 a.m.

10:00 a.m.

10:20 a.m.

10:20 a.m.

10:40 a.m.

10:40 a.m.

11:00 a.m.

11:00 a.m.

11:20 a.m.

11:20 a.m.

11:40 a.m.

11:40 a.m.

DESIGN TEAM

Michael Mehall, Nicholas Schooley

Daniel Gaona, Kyoungho Kim, Ahra Shall

Kenneth Bowman, DeAnna Doan

Kyle Crayne, Peter Koenigsknecht, Adam Sajdak

Jared Dorvinen, Bobby Fuentes, Dane Marsack

Matthew Pawlicki, Peter Schultz, Nicholas Wilson

Jarrold Heck, Andrew Kristufek, Benjamin Wilburn

Benjamin Ambrose, Erika Crosby, Khoa Nguyen

Jonathan DiClemente, Jonathan Luszczakoski, Justin Mrkva

Blaine Benson, Scott Hall, Katherine Hilton

Jeffrey Narkis, Kyle Schubel, Brian White

Jayson Blough, Nicholas Kuuttila, Jiawei Qin

C.J. Maines, Patrick O'Malley, Joseph Ray

Eric Beatham, Anthony Han, Ryan Lureau

Michael Aurino, Peter Bentley, Matthew Witmer

Gerald Gentz, Kyle Justus, Michael O'Brien

Hansen Ma, Andrew Nuttall, Jared St. Aubin

Christopher Chorny, Austin Deneff, Thomas Klotzbach

Matthew Fisher, Tyler Jaynes, Kurt Northrop

Joshua Baack, Andrew Cooper, Christopher Matthes

Nur Azan Joned, Yirang Liu, Camille McCall



RADIOACTIVE WASTE CONTAINER REMOVAL DEVICE

Instructor: Alfred C. Loos

TA: David Schrock

PROBLEM STATEMENT

Students in ME 471 were challenged to design and build a model of a device for moving a cylinder containing radioactive waste. The device was designed to pick up, rotate, and move a 7.5 in long x 2 in. diameter cylinder containing the radioactive waste weighing about 450 g. The cylinder, stored in the reactor building on a horizontal rack, must be picked up, rotated into the vertical position and transported through the containment area to a support where the cylinder will be stored in the vertical position until removal. The device must be able to reverse the process in order to move an empty cylinder weighing about 275 g into the reactor building.

The *performance function* of each device is determined based on a weighted sum of the following normalized objectives and constraints:

- Minimize mass
- Minimize cost
- Minimize the number of inputs required to operate the device
- Meet failure constraints (static and fatigue)
- Meet marketing constraints (integrate the product logo into the design)

The team with the *highest performance function* will be declared the winner of the ME 471 Design Day Competition.

Team	Step 1	Step 2	Design Team
	Time	Time	
1A	8:30	8:42	Ryan Aenis, Matthew Bur, Tyler Haley, Jiantao Liao
2B	8:42	8:54	Zachary Albright, David Crouse, Thomas Hallahan, Franklin Luchini, Trevor Shane
3A	8:54	9:06	Corey Anderson, Ross Dudgeon, Karsten Harns, Raul Maghiar, Corey Silvis
4B	9:06	9:18	Caitlin Bailey, Alexander Dutch, Christoph Hierl, Brian McClure, Michael Skierski
5A	9:18	9:30	Sam Balasz, Brian Farber, Daniel Holmes, Kyle Melzer, Scott Smith
6B	9:30	9:42	Jonathan Bancroft, Charles Ferreira, Zachary Hoyle, Kevin Miller, Cory Snowdin
7A	9:42	9:54	Shannon Beard, Kellen Fitzpatrick, Yueyao Hu, Patrick O'Malley, Joel Stcyr
8B	9:54	10:06	Shaun Bezinque, David Gaunt, Kyle Hyst, Colin Perrault, Isaac Steinbrunner
9A	10:06	10:18	Kyle Biega, Douglas Geiger, Marcus Johnston, Isaac Platte, Kevin Svacha
10B	10:18	10:30	Nicholas Blancke, Cameron Gibson, Kameron Kline, Nicholas Putman, Kyle Sweet
11A	10:30	10:42	William Blancke, Todd Graham, Lukasz Kurczab, Andrew Putz, Zachary Timpf
12B	10:42	10:54	Jordan Bowman, Zachary Graham, Nicholas Lannes, Daniel Pylar, Jonathan Tuse
13A	10:54	11:06	Brendan Brown, Christopher Griffith, Paul Laymon, Sylvia Reiser, Xiangyu Wang

Step 1: Weigh the device and mount it to the aluminum base plate.

Step 2: While one team member delivers the one-minute pitch, the other team members prepare for the final test.

A: Set-up and test device at Station 1

B: Set-up and test device at Station 2

ME 478

9:00 a.m. –11:20 a.m.
First Floor
South Porch



AMPHIBIOUS VEHICLE DESIGN

INSTRUCTOR: Dr. Patrick Kwon

The main objective for the course is to design and produce the amphibious vehicle for the track announced in class while integrating the engineering knowledge gained during the students' engineering education at MSU. Starting from an individual project and progressing to a team project, each team must produce an amphibious vehicle through a series of design and manufacturing tasks. Each student needs to contribute individually as well as collaboratively to accomplish a series of tasks with CAD/CAM packages, CNC machining, rapid prototyping, testing, etc. At the end of semester, three teams will compete in a race on Design Day.



Teams and members

Group A

Josh Baack
C. Mushuri
Trevor Shane

Group B

Brendan Brown
Mark Dawson
Joshua Dewalt

Group C

Deanne Doan
Derek Sabiston
Joel St. Cyr

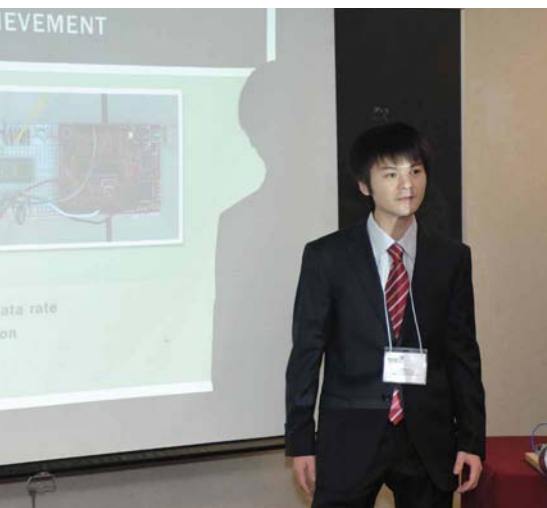
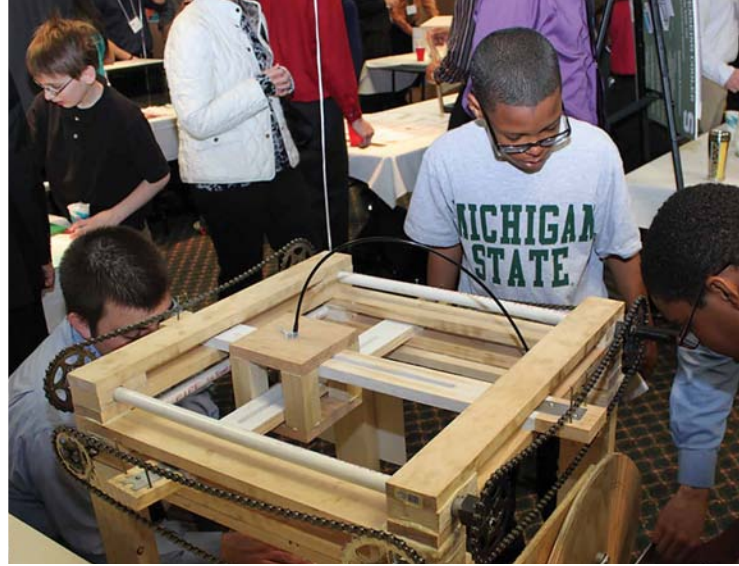

ME 481

8:00 a.m. – Noon
Third Floor
Lake Superior Room
and Fourth Floor
Tower Room



MECHANICAL ENGINEERING PROJECTS

PRESENTATION SCHEDULE — Lake Superior and Tower Rooms

Course Coordinator: Professor Clark Radcliffe

Faculty Advisors: Professors Averill, Brereton, Engeda, Jaber, Naguib, Pence, Pourboghra, Priezjev, Somerton and Wichman

Tower Room

Time	Project Sponsor(s)	Professional Advisor(s)	Faculty Advisor (s)	Project Title
8:00 a.m.	American Hydromech	T. Droste	A. Naguib	Solid Particle Contaminant Test Stand
8:25 a.m.	Robert Bosch, LLC	T. Graham M. Thorington	T. Pence	Fuel Return Line Service Tool for Diesel Piezoelectric Injector Systems
8:50 a.m.	Chrysler LLC	M. Butler	R. Averill	Front Seat Adjustable Armrest
9:15 a.m.	Ford Motor Company	M. Saunders	F. Jaber	Direct Connection of Fuel Vapor Hose
9:40 a.m.–10:00 a.m. Break				
10:00 a.m.	Louis Padnos Iron & Metal Company	B. Herweyer	F. Pourboghra	Inductive Proximity Sensor
10:25 a.m.	Whirlpool Corporation	A. Tenbarga	I. Wichman	Adjustable Ice Level Control for an Ice Maker
10:50 a.m.	Whirlpool Corporation	R. Pereira G. Wu	G. Brereton	Solar Powered Refrigerator
11:15 a.m.	Whirlpool Corporation	L. Wohlgamuth	G. Brereton	Variable Temperature Water Dispensing System

Lake Superior Room

8:25 a.m.	Nexteer Automotive	J. Hafeli R. Herring N. von Matt C. Walsh	T. Pence	Optimization of Torsion-Bar Component Design
8:50 a.m.	Rennco LLC	B. Bowerman	T. Pence	Lift Seal-Pouch Seal Validation
9:15 a.m.	The Appropriate Technology Collaborative	J. Barrie D. Rimatzki	C. Somerton	Solar Coffee Dryer
9:40 a.m.–10:00 a.m. Break				
10:00 a.m.	Heartwood School	J. Janicki C. Meyer	C. Somerton	Interactive Garden Additions
10:25 a.m.	Heartwood School	J. Janicki	N. Priezjev	MOVE Delivery Cart
10:50 a.m.	Lansing Schools K-8 STEM Academy	D. Graham	C. Somerton	Year-Round Vericomposting Bin
11:15 a.m.	Peckham	D. Harder	A. Engeda	Recyclable Fabric Defect Marking Methods

American Hydromech: Solid Particle Contaminant Test Stand

Founded by Timothy A. Droste in 2007, American Hydromech has provided design and development engineering support, VAVE/DFMEA workshops, DV test, and prototype assembly and test to a number of OE, Tier I, and Tier II customers.

This semester, American Hydromech of Howell, Michigan was contracted to establish a set of fundamental design rules to guide the design and development of second-generation oil test supply modules used to execute petroleum filter multipass performance tests. Using these rules, a detailed Test Stand Design Specification (TSDS) document, 3-dimensional CAD model, and complete Bill of Materials (BOM) were created, allowing the construction of such a test facility. A key attribute includes “seamless” integration with existing dilution, injection, and data acquisition modules.

The objective of this project was to research and collate applicable government and industry standards, using them to formulate a generic Design Rule document, as well as a detailed Test Stand Design Specification for a specific oil test stand. These documents are supported by the 3-dimensional CAD model, requisite 2-D drawings, and BOM. Once these engineering documents were approved, the team constructed a Solid Particle Contaminant Oil Test Supply compliant with the aforementioned Design Rules; ISO-16889, 4548-12, and 19438 multi-pass standards; and applicable industrial safety regulations. This fully functional test stand supplies test fluid at an automatically controlled flow rate, compensates for temperature and pressure variation, keeps test contaminant in suspension, and provides for quick, easy



routine maintenance. By following this detailed procedure, the team is confident that the final test stand will successfully test oil filters for years to come.

*...The American Hydromech
Student Design Team*



Mr. Droste, P.E.

As IC engine and hydraulic systems evolve, the criticality of operating clearance and the negative effects solid particle contaminants have on running surfaces becomes more important. The effectiveness of filters used to protect these surfaces must be measured precisely, reliably and with equipment and methods that can be duplicated. Furthermore, many of the test methods involve repetitious actions, e.g. contaminant batch adds, that if automated would allow test operators to be more productive.

Timothy A. Droste, P.E.
American Hydromech



Prof. Naguib

Project Sponsor
American Hydromech
Howell, Michigan

Professional Advisor
Timothy Droste, P.E.

Faculty Advisor
Prof. Ahmed Naguib

Team Members and Home Towns
Erika Crosby
Goodrich, Michigan

Andrew Kristufek
Troy, Michigan

Matthew Pawlicki
Buffalo, New York

Peter Schultz
Fairwater, Wisconsin

Nicholas Wilson
Cincinnati, Ohio

Robert Bosch, LLC: Fuel Return Line Service Tool for Diesel Piezoelectric Injector Systems

Robert Bosch, LLC fosters an authentic culture of synergistic concurrent engineering that is responsible for innovations that are truly “invented for life.” Moreover, the potency of these innovations is reflected in the staggering 3,800 patent applications filed in the year 2010 alone, and these data provide a measure of the creative engineering workforce at Robert Bosch, LLC.

Since pioneering the automotive industry’s first fuel injection system with a high-pressure electric fuel pump in 1967, Robert Bosch, LLC has been recognized as the worldwide leader in fuel injection technology and design. The introduction of diesel piezoelectric fuel injectors for high-performance diesel engines is further evidence of the company’s state-of-the-art technologies.

Founder Robert Bosch stated, “I would rather lose money than trust. The integrity of my promises, the belief in the value of my products and of my word of honor have always had a higher priority.” The company’s staunch commitment to providing customers with the support they need is clearly evidenced today. Engineers were quick to initiate a product development project when service technicians informed them that they were not able to efficiently remove the fuel return lines that connect to the diesel piezoelectric injectors, instead breaking the connector and risking the integrity of the fuel injectors to save time.

This project targets the design and manufacture of a cost-effective service tool and the associated operating procedures to quickly and easily remove the fuel return lines from the diesel piezoelectric injectors used in multiple diesel engine applications in



the United States. The primary goals of the tool are to reduce service technician down-time and mitigate unnecessary warranty costs due to broken injector connectors, thereby creating an innovation worthy of being “invented for life.”

...The Robert Bosch, LLC Student Design Team



BOSCH

Invented for life



Mr. Thorington



Mr. Graham

Bosch customers of Diesel Piezoelectric Injector fuel systems are requesting more service bay-friendly tools and processes for servicing the fuel return lines.

Currently, such a tool does not exist and, as a result, the warranty costs on these systems are higher than need be due to connector breakage. Development of a service tool would allow Bosch to bring to market a service tool which satisfies multiple customer needs and reduce warranty costs.

Mr. Matt Thorington,
Senior Engineer, Diesel Fuel Systems
Robert Bosch, LLC



Prof. Pence

Project Sponsor
Robert Bosch, LLC
Farmington Hills,
Michigan

Professional
Advisors
Mr. Terry Graham
Mr. Matt Thorington

Faculty Advisor
Prof. Thomas Pence

Team Members
and Home Towns
Gerald Gentz
Addison, Michigan

Kyle Justus
Midland, Michigan

Michael O'Brien
Midland, Michigan

Gregory Thomas
Brighton, Michigan

J.T. Whitman
DeWitt, Michigan

Chrysler LLC: Front Seat Adjustable Armrest

Since 1925, Chrysler has maintained its place as one of the leading automobile manufacturers in the world. Founder Walter P. Chrysler once said, “the real secret of success is enthusiasm,” an idea which still resonates throughout the corporation. Even through the rough economy of the past several years they continue to forge on. Updating their vehicle line and staying true to their customer base has granted them success over their long history.

The Chrysler Seat Team has unveiled numerous innovative designs to maintain and exceed customer satisfaction. These innovations are presented in their line of minivans and include the Stow ’n Go storage feature and Swivel ’n Go swiveling second row seats. Offering class-leading seat configurations gives Chrysler an edge over their competitors.

Chrysler is interested in offering seats with an adjustable armrest in automobiles that cannot use the center console for that function. The primary vehicles that would feature this armrest are their line of minivans. Current armrests are limited to only one engaged position, which lacks the personal fit needed in a comfortable, luxurious automobile. The adjustable armrest design aims at being height adjustable as well as angle adjustable to accommodate customers across the spectrum.

The student team is assisting Chrysler by creating a concept design that meets structural requirements, is lightweight, and user-friendly. Using motors to power the armrest’s adjustability allows infinite fine-tuning in both the vertical and angular directions. Users of all sizes will enjoy their new adjustable armrest adaptable just for them.

...The Chrysler Student Design Team



Mr. Butler



Prof. Averill

Chrysler LLC is known to have a competitive advantage in the automotive industry with regards to new and innovative features that delight our customers. Our Seat Engineering group has significantly contributed to this competitive advantage through the implementation of such innovations as Stow ’n go® and Swivel ’n Go® seating. This project is expected to increase our competitive advantage through the identification of the next opportunity and the development of a concept that will delight our customers.

Michael Butler
Design Responsible -- Front Seats
Chrysler LLC

Project Sponsor
Chrysler LLC
Auburn Hills, MI

Professional Advisor
Mr. Michael Butler

Faculty Advisor
Prof. Ronald Averill

Team Members and Home Towns

Scott Coy
Cadillac, Michigan

Andrew Mozer
Rochester Hills, Michigan

Scott Shaw
Haslett, Michigan

Ashley Swartz
Laingsburg, Michigan

Shawn Wright
Rochester Hills, Michigan

Ford Motor Company: Direct Connection of Fuel Vapor Hose

Ford Motor Company has been one of the leading companies in the automobile industry since its founding by Henry Ford in 1903. Henry Ford is most famous for his successful implementation of the assembly line in the company’s manufacturing facilities. Today, Ford Motor Company is headquartered in nearby Dearborn, Michigan, with a variety of quality vehicles on the market.

Our project involved working with the fuel system of a variety of Ford and Lincoln models. Per EPA requirements, fuel vapor must not escape into the atmosphere. For this reason, automobiles contain a carbon canister system to collect these harmful vapors. Currently, this system is connected to the fuel tank via hoses which attach with a costly quick connector device. Although a single quick connector may seem like an inexpensive component, the removal of such a part on a mass production scale has the potential to save Ford Motor Company a significant amount of money.

For our capstone design project, our team worked on a material cost reduction project within this carbon canister system. This project involved the potential elimination of the quick connector component at the hose connection port of the carbon canister. Various design alternatives were researched and evaluated based on specifications such as cost, ease of assembly, and potential failure modes. The most effective solution was then selected and pursued.

...The Ford Motor Company Student Design Team



Mr. Saunders

The primary benefit of this project to Ford Motor Company is reduced cost through the reduction of component parts and assembly process simplification. It will be initially targeted for introduction at one manufacturing facility but has the potential to be used in a variety of applications that use this type of hose connection, even beyond the carbon canister joint.



Prof. Jaber

Mark Saunders
Product Design Engineer
Ford Motor Company

Project Sponsor
Ford Motor Company
Dearborn, Michigan

Professional Advisor
Mr. Mark Saunders

Faculty Advisor
Prof. Farhad Jaber

Team Members and Home Towns
Eric Beatham
Livonia, Michigan

Anthony Han
Iron River, Michigan

Jeff Narkis
River Forest, Illinois

Kyle Schubel
Harrison Twp., Michigan

Brian White
Troy, Michigan

Louis Padnos Iron & Metal Company: Inductive Proximity Sensor

Louis Padnos Iron & Metal has sought to safely and efficiently recycle metals and other materials for over a century. They strive to use the newest and most effective technology in breaking down and processing these materials. The objective of the company is to provide comprehensive sorting of the scrap in order to reduce waste.

Padnos receives a broad array of unsorted materials. In order for these constituents to be processed, they must be sorted by type. After a piece of metal is identified it needs to be separated from the rest of the scrap. One of their primary methods of sorting is an array of UHMW Polyethylene displacers. When these displacers are fired they force the selected material out of its path and into an appropriate container.

While this system is very effective, at the current state the displacers are achieving an average of 1 million cycles before failure. The parts in place have been known to achieve as many as 10 million cycles. Production of these displacers needs to be optimized to increase the overall life of the units.

By focusing on increasing the fatigue resistance of the individual parts of the system as well improving their orientation and the fabrication process, system life will increase. The optimization of the displacers will save Padnos both time and money.

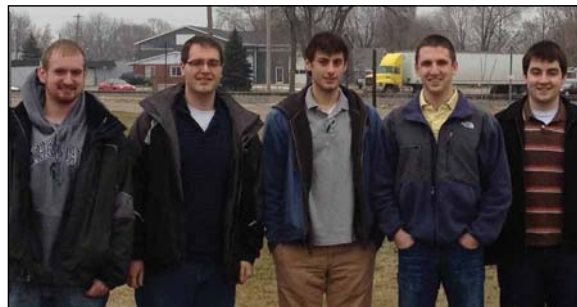

...*The Louis Padnos Iron & Metal Student Design Team*



Mr. Herweyer

The induction sensor project will enhance our current ISS machines, giving us the ability to detect and recover smaller scrap pieces of copper wire from our non-ferrous residue at our eddy current plant; this will give Padnos an opportunity to create value from a product which currently has low or no value.

-Bob Herweyer
Louis Padnos Iron & Metal



Prof. Pourboghrat

Project Sponsor
Louis Padnos Iron & Metal Company
Holland, Michigan

Professional Advisor
Mr. Bob Herweyer

Faculty Advisor
Prof. Farhang Pourboghrat

Team Members and Home Towns
Peter Bently
Troy, Michigan

Ryan Lureau
Lansing, Michigan

Jonathan Luszczakoski
Rochester Hills, Michigan

Christopher Matthes
Bloomfield Hills, Michigan

Benjamin Wilburn
Jackson, Michigan

Whirlpool Corporation: Adjustable Ice Level Control for an Ice Maker

Whirlpool Corporation is a global leader in home appliances marketed in almost every country around the world. It manufactures appliances across all major categories, including fabric care, cooking, refrigeration, dishwashers, countertop appliances, garage organization, and water filtration. Whirlpool instills innovation as a core expertise within its company, thus promoting new ideas to deliver endless quality to its consumers. Whirlpool's passion for excellence has prompted it to provide a solution to today's primary problem in refrigeration systems equipped with automatic ice dispensers.

Ice dispensing systems function to provide the consumer with ice at any given time. Therefore, it maintains the maximum capacity of its container by replenishing any used ice. This aspect of an ice-dispensing system results in unused ice, which absorbs food odors over time from the air that circulates throughout the refrigerator. This results in ice with undesirable surface finish and taste.

Whirlpool has tasked the team with providing a solution to this universal problem in automatic ice-dispensing systems. The goal is to help reduce the amount of unused ice and retain ice with a good taste and surface finish. This was accomplished by providing Whirlpool with unique solutions that can be implemented in existing refrigeration units. The team supplied Whirlpool with new ideas, CAD models, and a prototype incorporating leading-edge, infrared technology that embodied their passion for innovation.

A solution was delivered that would ultimately allow the consumer to control the amount of ice collected in the container, thus improving the quality of ice.

...The Whirlpool Student Design Team



Mr. Tenbarge



Prof. Wichman

Whirlpool Corporation is a world class appliance leader that strives to bring the best experience to the consumer through constant design improvements and leading innovations. This project addresses the consumer by enabling a better ice experience. Specifically the project addresses the consumer need for allowing the ice supply volume to be customized based on consumer needs without compromising key features Whirlpool consumers are expecting. These features include: best-in-class ice availability, maximizing usable storage space, and must meet Whirlpool's and government's appliance standards. This provides the end consumer a quality appliance they can depend on for years of service.

Andrew Tenbarge
Engineer I&W Technology
Whirlpool Corporation

Project Sponsor
Whirlpool Corporation
Benton Harbor,
Michigan

Professional Advisor
Mr. Andrew Tenbarge

Faculty Advisor
Prof. Indrek Wichman

Team Members and Home Towns

Ken Bowman
Riga, Michigan

Robert Conley
Saginaw, Michigan

DeAnna Doan
Merrill, Michigan

Camille McCall
Detroit, Michigan

Kurt Northrop
Troy, Michigan

Whirlpool Corporation: Solar Powered Refrigerator

Established in 1911 in Benton Harbor, Michigan, Whirlpool Corporation has been designing and manufacturing home appliances for over 100 years. Since then Whirlpool has managed to acquire and develop a wide variety of brands such as Maytag, KitchenAid, Jenn-Air, and Amana to meet the demands of today's consumer. As a multi-national company and "the largest home appliance manufacturer in the world," Whirlpool currently employs more than 70,000 people and generates annual revenues of over \$18 billion. Engineers at Whirlpool are constantly creating new products to meet the needs of consumers as well as striving to increase the efficiency, performance, and ease of use of the plethora of consumer goods which they already produce including home appliances, HVAC systems, and a wide array of kitchen products. The Whirlpool – Gold appliance line, including the Gold 25.5 Cu. ft french door refrigerator used in this project, is one of the best-selling product lines on the U.S. market.

Currently, Whirlpool is investigating the use of alternative energy systems in its home appliances. In the future, the implementation of these systems will not only benefit the environment but also consumers by reducing total household energy costs. These technologies will also prove beneficial to those living "off the grid" either by choice or in remote areas where access to municipal power is not possible. The choice of a refrigerator being used in this project was not by chance. The energy consumption of an efficient refrigerator while running may be equivalent to that of a 60 or 80 Watt light bulb; however over time, this adds up to 7% of



the total power used by an average household. This project, as well as continuing research on home energy production and consumption, will enable Whirlpool to incorporate alternative energies into future product designs and maintain its status as the world's leading appliance manufacturer.

...The Whirlpool Student Design Team



Mr. Pereira

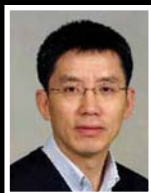

Dr. Wu

This project will evaluate solar energy as an alternative way to power household refrigerators. Solar powered refrigerators use renewable energy, thus are environmentally friendly. Whirlpool takes environmental responsibilities very seriously and continues to develop innovative solutions that minimize their impact on environment while making consumers' lives easier.

Mr. Roberto Pereira, Lead Engineer
Advanced Development-Refrigeration, GPO
Whirlpool Corporation



Prof. Brereton

Project Sponsors
Whirlpool Corporation
Benton Harbor,
Michigan

**Professional
Advisors**
Mr. Roberto Pereira
Dr. Guolian Wu

Faculty Advisor
Prof. Giles Brereton

**Team Members
and Home Towns**
Jared Dorvinen
Houghton, Michigan

Bobby Fuentes
Sturgis, Michigan

Dane Marsack
Allenton, Michigan

Ahra Shall
Seoul, South Korea

Yingxa Wang
Shenyang, China

Whirlpool Corporation: Variable Temperature Water Dispensing System

Whirlpool Corporation is a major manufacturer of home appliances. It was founded in 1898 and is based in Benton Harbor, Michigan. Its main product lines include laundry appliances, refrigerators, cooking appliances, dishwashers, mixers, and other small household appliances. Whirlpool's focus is to create value and loyal customers and to be inside every home and in every room.

Following this vision, Whirlpool has determined that consumers want the ability to control the temperature of water dispensed from their refrigerators. Refrigerators currently available in the market only dispense cold water, so the main project task is to design a temperature regulating system. Desired temperatures vary by region; for this project, a range of water temperatures from cold to ambient (42°F -70°F) is required to satisfy the needs of European and Latin American consumers. Ideally, the proposed system could be used as a base model for a system that provides a full temperature range, from boiling to cold, to be used in the North American market.

Currently, water is gravity-fed and filtered in a door-mounted reservoir where it is kept at refrigerator temperature. Methods including flash heating, mixing streams of different temperatures, and other methods, were researched to come up with the best solution meeting the space, energy efficiency, and cost



standards required by Whirlpool. A variable temperature system has been designed for the European gravity-fed, refrigeration market. The same concept can be adapted for a force-fed system that would be plumbed from a water line.

... *The Whirlpool Student Design Team*



Ms. Wohlgamuth



Prof. Brereton

Refrigerator ice and water dispensers are a desired feature for the average consumer today. However, most refrigerator water dispensers only dispense cold water. The Variable Temperature Water Dispenser project will allow the consumer to control the temperature of water being dispensed. Variable temperature water dispensing is desired globally by consumers and will differentiate Whirlpool in the marketplace. Whirlpool continues to lead in the home appliance industry by integration of innovative and consumer driven features like the Variable Temperature Water Dispenser.

Lindsey Wohlgamuth
Whirlpool Corporation

Project Sponsor
Whirlpool Corporation
Benton Harbor, Michigan

Professional Advisor
Ms. Lindsey Wohlgamuth

Faculty Advisor
Prof. Giles Brereton

Team Members and Home Towns
Nilutpol Basumatari
Sivasagar, India

Dustin Colthorp
DeWitt, Michigan

Fernando Vasquez Dheming
San Salvador, El Salvador

Kyoungho Kim
Seoul, South Korea

Brady Thom
Livonia, Michigan

Nexteer Automotive: Optimization of Torsion-Bar Component Design

The goal of this project is to optimize the Torsion-Bar component of the electric power steering (EPS) systems manufactured by Nexteer Automotive. The redesign of the component reduces the overall cost of the component by improving manufacturability, ease of assembly, and reliability. This was achieved by addressing critical factors of the torsion bar including mechanical loading, fatigue life, material composition, connection method, and total assembly package size, while maintaining the necessary performance standards.

Several design alternatives were investigated to increase the effectiveness of the torsion bar and retain its functional properties. The torsion bar is the element of the EPS system that allows angular misalignment between the steering wheel and the assist system. A sensor measures this misalignment and actuates an electric motor, supplying power assistance to the driver turning the road wheels of the vehicle. The reliable angle of twist, material integrity, and manufacturability of the part were immediately identified as key characteristics of the torsion bar.

To maintain a reliable angle of twist while reducing part cost, both the end connections of the torsion bar and the torsion bar material could be altered. Two of the design alternatives included a torsion bar with square or octagonal end geometries. Prototype torsion bars were also created from steels of different carbon

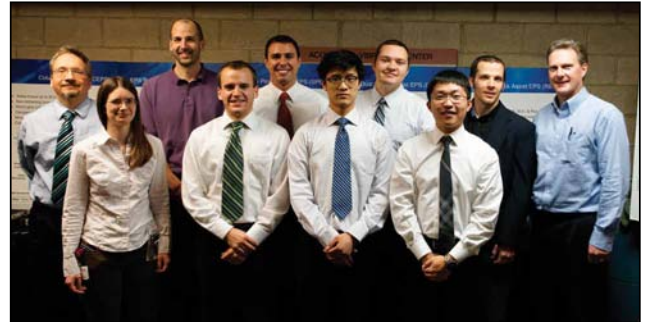

contents under current specifications to investigate the effect of changing the composition. Finally, new material hardening methods were researched at length to inspect the feasibility of using a less expensive material and hardening it to avoid costly manufacturing errors, namely galling.

...The Nexteer Student Design Team



Mr. Herring

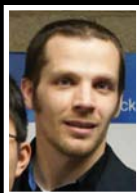

Mr. von Matt



Mr. Walsh



Ms. Hafeli



Prof. Pence

Nexteer Automotive is a leader in steering systems worldwide with innovation being the foundation for the business. The torsion bar is a critical component in electric power steering (EPS) systems and provides the mechanical interface for the torque sensor performance handling. The optimization of the torsion bar design will enable Nexteer to continue to provide the highest quality and reliable systems globally while minimizing cost through component design, material selection and manufacturing considerations.

Neal Roller
Engineering Manager
Nexteer Automotive

Project Sponsor
Nexteer Automotive
Saginaw, Michigan

Professional Advisors

Ms. Jennifer Hafeli
Mr. Randy Herring
Mr. Nik von Matt
Mr. Chris Walsh

Faculty Advisor

Prof. Thomas Pence

Team Members and Home Towns

Jayson Blough
Lansing, Michigan

Nick Kuuttilla
Farmington Hills, Michigan

Jiawei Qin
Peoples Rep. of China

Justin Raymond,
Farmington Hills, Michigan

Michael Wong
Bloomfield Hills, Michigan

Rennco LLC: Lift Seal-Pouch Seal Validation

Rennco LLC is a company established in 1969, which specializes in sealing systems for various bag applications. Rennco entered the market by introducing a new, simple, cost-effective sealing system for various products packaged in polyethylene, polyolefin, and PVC films. Rennco's trademark is its low-maintenance, continuously heated and coated sealing bar, which provides sealing without the smoke or odor associated with melting plastic. Currently, Rennco manufactures custom packing machinery and systems. Its customers include domestic and international food service disposable products manufacturers. Rennco's machinery line ranges from semi-automatic bagging systems to fully-automatic bagging machines.

Currently, one of Rennco's best-selling products is its Lift Seal Heat Sealer LS18. This device is a medical application, as it seals sterilization-ready bags for hospitals. It makes a half-inch-wide seal with approximately 30PSI of sealing pressure for a duration of 2.5 seconds. This product has been unchanged for 20 years.

The project goal is to sense and record temperature, pressure, and time of sealing. If a seal's captured data does not meet the specified constraints, a visual alarm must light up, indicating that sealing was not successful. Adding these features to the product would put Rennco's lift seal heat sealers in the market with much more expensive devices that have similar capabilities, at a much lower price. Currently, the product has adjustable temperature settings, and a temperature sensor.

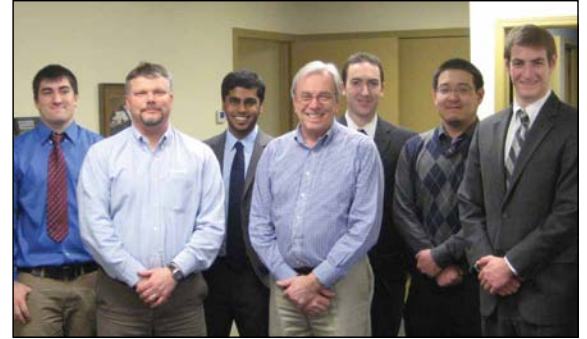

Research was conducted on controllers and pressure sensors. Programming the controller was a crucial point, and knowledge in programming language was required. It was also important to have the data recorded in a user-friendly program with the end consumer being hospital faculty.

...*The Rennco Student Design Team*



Mr. Bowerman



Prof. Pence

The Lift Seal is a standardized commodity that seals medical pouches with surgical instruments to be sterilized. This unit has been fundamentally unchanged for 20 years. To increase market share, Rennco LLC needs to develop new features that will allow for an increased sales volume of 20% - 30%.

Brian Bowerman
Director of Engineering
Rennco LLC

Project Sponsor
Rennco LLC
Homer, Michigan

Professional Advisor
Mr. Brian Bowerman

Faculty Advisor
Prof. Tom Pence

Team Members and Home Towns
Josh Baack
Canton, Michigan

Andrew Cooper
Troy, Michigan

Adi Kosgi
Canton, Michigan

Hansen Ma
China

David Marsh
Ypsilanti, Michigan

A Shell Oil Company Humanitarian Project: The Appropriate Technology Collaborative: Solar Coffee Dryer

The Appropriate Technology Collaborative was founded with the goal of creating sustainable technologies to promote economic growth and improve the quality of life for low income people around the world. It works with local groups and nonprofit organizations to develop culturally sensitive, environmentally responsible, and locally repairable solutions to everyday issues. Previous ATC projects include Bamboo Reinforced Concrete, BioFuels, Solar/LED Lighting, and Solar Refrigeration.

Farmers in rural Guatemala grow, harvest, and dry coffee beans that are sold to be roasted. The drying of the beans is directly related to the quality of the coffee produced and its selling price. Conditions in the mountainous region surrounding Lake Atitlan are good for growing coffee; however, the drying process used is less than optimal. Generally, beans are spread out on a tarpaulin or concrete slab to be dried by the sun.

The goal of the design team is to increase the effectiveness of the coffee drying process by developing a solar coffee dryer. The dryer is designed to be constructed using materials and methods available in country that minimize cost and environmental impact. Solar processes to be investigated are passive, active, water-based, and thermal storage.

The final design utilizes a solar collector in combination with a thermal mass storage system. The thermal mass storage



system is a compost pile that can also create heat or crushed rock that can store heat to be used in the drying process. The goal is to introduce several heat sources that can be combined to decrease the amount of time required to dry the coffee and increase the quality of the coffee.

...The Appropriate Technology Collaborative Student Design Team



Mr. Barrie



Mr. Rimatzki



Prof. Somerton

The Appropriate Technology Collaborative was founded to work side-by-side with communities in developing countries to design, develop, demonstrate, and distribute affordable and sustainable technological solutions that empower people and promote dignity. The design of a low-cost solar coffee dryer will allow small-scale rural farmers to dry their own coffee beans, improve the quality of their product and increase family income.

John Barrie
The Appropriate Technology Collaborative

Project Sponsor
The Appropriate Technology Collaborative
Ann Arbor, Michigan

Professional Advisors
Mr. John Barrie
Mr. Doug Rimatzki

Faculty Advisor
Prof. Craig Somerton

Team Members and Home Towns
Matt Fischer
Dimondale, Michigan

Tyler Jaynes
Comstock Park, Michigan

Charles Maines
Alto, Michigan

Joseph Ray
Northville, Michigan

A Shell Oil Company Humanitarian Project: Heartwood School: Interactive Garden Additions

Hearthwood School is located in Mason, Michigan and serves students in the Ingham Intermediate School District with moderate to severe cognitive impairments, severe multiple impairments, autism spectrum disorders, and traumatic brain injuries. The ages of Heartwood students range widely, between 3 and 26 years old. Teachers and faculty of the school work hard to support the students and enable them to reach their full potential.

The objective of the project was to provide an opportunity to engage the students mentally while simultaneously improving their physical strength. This objective was achieved through the addition of interactive structures to the existing children's garden at Heartwood School. These structures incorporate multiple senses and stimulate students both mentally and physically while providing an enjoyable experience for all visitors.

Heartwood School uses the Mobility Opportunities Via Education/ Experience (MOVE) curriculum, which is designed to help students improve their ability to sit, stand, walk, and transition from one position to another. The project developed by the Heartwood School Student Design Team fits well with the MOVE curriculum because of the focus on interactivity and physical strengthening.

The interactive structures include an archway that incorporates a variety of senses using moving blocks and a flagpole with a variety of visually stimulating attachments. The archway encompasses a gravel path through the garden and has interactive elements on both sides of the



supports. One element is an abacus with sliding wooden disks. The freestanding flagpole is operated by a simple mechanism that allows the students to raise and lower the flag or any other accessory with ease.

...*The Heartwood School Student Design Team*



Ingham
Intermediate
School District



Ms. Meyer



Ms. Janicki



Prof. Somerton

Heartwood School utilizes the MOVE Curriculum which is a research-based program shown to improve functional mobility skills. Mobility and strength empower children with severe physical disabilities to better direct their own lives. One of the activities that our students enjoy is going outside to visit our sensory garden. Some students walk independently, but others use walkers, wheelchairs, or other adaptive equipment to move around.

Joanne Janicki
Physical Therapist

Cheryl Meyer
Certified Occupational Therapist Assistant

Project Sponsor
*Heartwood School
Mason, Michigan*

**Professional
Advisors**
Ms. Joanne Janicki
Ms. Cheryl Meyer

Faculty Advisor
Prof. Craig Somerton

**Team Members
and Home Towns**
Chris Chorny
Stevensville, Michigan

Jeff Klegon
White Lake, Michigan

Tom Klotzbach
Traverse City, Michigan

Charlie McGovern
Holland, Michigan

Stephanie Vasi
Troy, Michigan

A Shell Oil Company Humanitarian Project: Heartwood School: MOVE Delivery Cart

Hearthwood School serves students in Ingham County who are eligible to receive services under the categories of moderate and severe cognitive impairments, severe multiple impairments, autism spectrum disorders, and traumatic brain injuries. Heartwood staff works with local school districts and families to provide center-based programs and services to students.

In an effort to increase functionality and motor abilities, physical activity is integrated into the students' daily activities. Heartwood School utilizes the MOVE curriculum to achieve this. The MOVE Curriculum is a top-down, activity-based curriculum designed to teach students the basic, functional motor skills of sitting, standing, and walking needed for life within the home and community environments. The curriculum combines natural body mechanics with an instructional process to help students acquire increasing motoric independence.

The project tasks include incorporating the MOVE curriculum into a cart that is used for daily activities. The cart will be used to improve motor abilities while completing daily activities such as transporting food from room to room, delivering mail, and returning lunch trays. The design will engage students in physical processes that will contribute to the movement of the cart.

Currently, Heartwood School is using a cart that was a previous Michigan State University capstone project. The standard cart attaches to a student's mobility equipment and is used on a daily basis. However, it does not include any physically engaging features.



Research on the MOVE curriculum, propulsion methods, available equipment, attachment systems, and assistive technology was performed to find the best design. Designs were created in NX 8.0, a three-dimensional modeling program. After numerous revisions a prototype was created and then tested at the Heartwood School. Constraints such as safety, reliability, and the versatility of the students' hardware and physical abilities were closely monitored throughout the design process.

...The Heartwood School Student Design Team



Ingham
Intermediate
School District

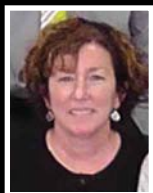

Ms. Janicki



Prof. Priezjev

The project will design and build a cart that would allow our students to run errands, make deliveries and strengthen their extremities. The project will enhance the educational day of the physically impaired students. Increased abilities to functionally mobilize decreases the burden of care for families and other care providers. These increased abilities also bring new opportunities for fuller participation and involvement in family life, school life and integration and inclusion in the wider community. Additionally, students enjoy the interactions and increased communication with others on their errands.

Ms. Joanne Janicki
Heartwood School

Project Sponsor
Heartwood School
Mason, Michigan

**Professional
Advisor**
Ms. Joanne Janicki

Faculty Advisor
Prof. Nikolai Priezjev

**Team Members
and Home Towns**
Austin Deneff
Holland, Michigan

Josh DeWalt
Warren, Michigan

Andrew Nuttall
Stephenson, Michigan

Nick Schooley
Grand Ledge, Michigan

Jared St. Aubin
Rochester Hills, Michigan

A Shell Oil Company Humanitarian Project:

Lansing Schools K-8 STEM Academy: Year-Round Vermicomposting Bin

The Lansing School District has shown a commitment to recycling at all of its schools. The newest school to open in the district, the Lansing Schools K-8 STEM Academy, is a magnet school with a focus on science, technology, engineering, and mathematics. The school would like an environmentally-friendly means with which to recycle cafeteria waste, similar to that found at other Lansing School District schools.

Vermicomposting is a process of breaking down organic matter using worms. During the winter months the compost freezes, rendering standard bins useless during much of the school year. To be useful, the Lansing K-8 STEM Academy needs a bin that will operate throughout the entire school year.

The Lansing Schools K-8 STEM Academy Student Design Team was asked to include the students of STEM Academy in the development of the vermicomposting bin to fit the school's needs. The 5th grade class at the STEM Academy was taught the engineering design process, tracked the team throughout the course of the development and construction of the box, and even performed experiments to gather data pertinent to the design of the bin. This bin will function not only to recycle cafeteria waste but also to teach the students of Lansing K-8 STEM Academy the basics of recycling and living an environmentally-friendly lifestyle.



Research on heating methods and insulation methods was done, as well as research looking into capturing the natural heat generated by the worms and the compost. The bin was designed to be accessible and safe for the students while operating with a minimal carbon footprint.

...The Lansing Schools K-8
STEM Academy Student
Design Team



Ms. Graham

By implementing a food waste converter system, our school will save money, help the environment, and aid in teaching the upcoming generation how to properly reduce waste that goes to landfills. The students will also use the compost produced in the school gardens, which will be a practical way of teaching botany and life cycles. To work along with the MSU engineering students on this project will not only teach our 5th graders how engineers solve problems but also will excite and interest them in engineering.

Diane Graham
Fifth Grade Teacher
Lansing Schools K-8 STEM Academy



Prof. Somerton

Project Sponsor
**Lansing Schools K-8
STEM Academy**
Lansing, Michigan

**Professional
Advisor**
Mrs. Diane Graham

Faculty Advisor
Prof. Craig Somerton

**Team Members
and Home Towns**
Khalifa Al Mansouri
Al Ain, United Arab
Emirates

Blaine Benson
Birmingham, Michigan

Scott Hall
Howell, Michigan

Katherine Hilton
Rochester, Michigan

Nur Joned
Kuala Lumpur, Malaysia

Peckham: Recyclable Fabric Defect Marking Methods

Peckham, Inc. is a non-profit business headquartered in Lansing, MI, which provides employment and training for people with disabilities and various other barriers to employment. Peckham offers opportunities for training and employment in apparel manufacturing, general manufacturing, business services, environmental services, and supply chain solutions.

The Apparel Manufacturing operations produce about 400,000 military fleece garments per month. This process results in a substantial amount of scrap fabric. Until recently, there has been no effective method of disposing of this waste in an environmentally-friendly manner. The REPREVE Textile Takeback Program is a new program by Unifi, a fabric company, which takes scrap fabric and recycles it into REPREVE, a yarn made of 100% recyclable fabric waste. Peckham is one of the first companies to participate in this program.

Peckham currently uses red and yellow tape to serve as flags for fabric defects or splices (end of a fabric roll). This tape is not compatible with the Unifi recycling process. In order to recycle the fabric, all of the tape must be removed by hand. Due to stringent recycling requirements, Peckham must be certain no tape has been sent along with the fabric to be recycled. Therefore, production is hindered by the labor intensive tape removal process.



The Peckham Student Design Team at Michigan State University has been tasked with designing a method of marking defects and splices that reduces the amount of time spent applying and removing the marks. The solution must still serve as a flag for the production floor and be easy to detect. The solution must also be cost effective and cannot have a negative impact on Peckham's customers.

...The Peckham Student Design Team



Ms. Harder

This project will enhance Peckham's ability to efficiently recycle 25,000 lbs. of fabric a month. It will save us wasted labor hours and landfill costs. It will aid us in becoming a leader in sustainable processing of apparel manufacturing waste.

Dana Harder
Marketing and Cut Coordinator
Peckham, Inc.



Prof. Engeda

Project Sponsor
Peckham, Inc.
Lansing, Michigan

Professional Advisor
Ms. Dana Harder

Faculty Advisor
Prof. Abraham Engeda

Team Members and Home Towns
Kyle Crayne
Maumee, Ohio

Andrew Grossman
Grand Rapids, Michigan

Peter Koenigsknecht
Lansing, Michigan

Adam Sajdak
Troy, Michigan

Greg Tenbusch
Bad Axe, Michigan

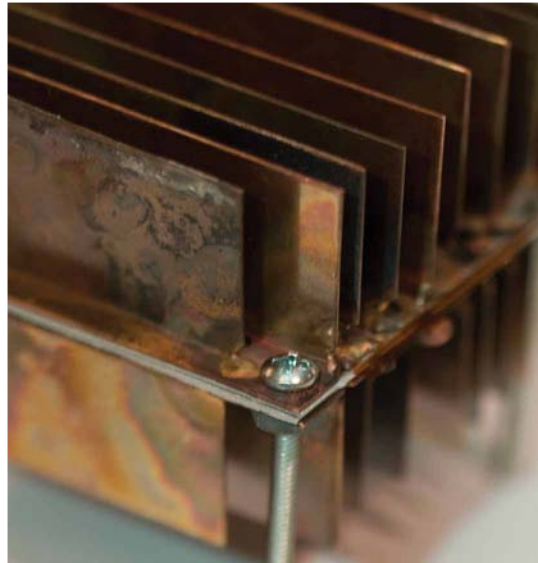

THANKS TO NORFOLK SOUTHERN

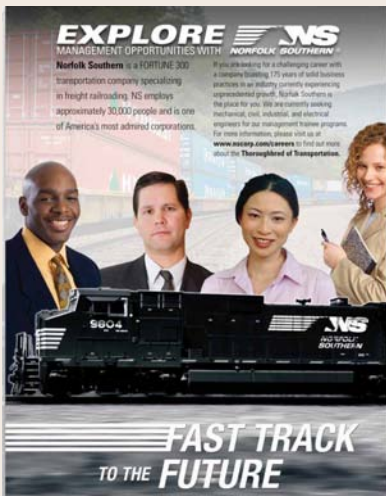

The Department of Electrical and Computer Engineering thanks Norfolk Southern for its generous financial support of Design Day. This support sponsored a design team, with their Triple Crown Services, and was used for production of this program and for other costs associated with Design Day, and for the infrastructure that allows our ECE Senior Capstone Design teams to work effectively on their industry problems.

Norfolk Southern Railway has a proud history, and today's NS includes not only the Norfolk and Western Railway and Southern Railway from which its name arose, but also all or large parts of many other historic railroads, such as the Pennsylvania Railroad, Nickel Plate Road, and Conrail. We are proud to have Norfolk Southern as a sponsor of Design Day! They recruit engineers (not locomotive engineers, but electrical engineers, computer engineers, etc.) at Michigan State University.

The Future of Transportation





A Portable Water Pump: Macheo Children's Centre

“Macheo Children's Centre is the home of 56 children and also outreach programs that enhance the lives of 8,000 other children in the community.”

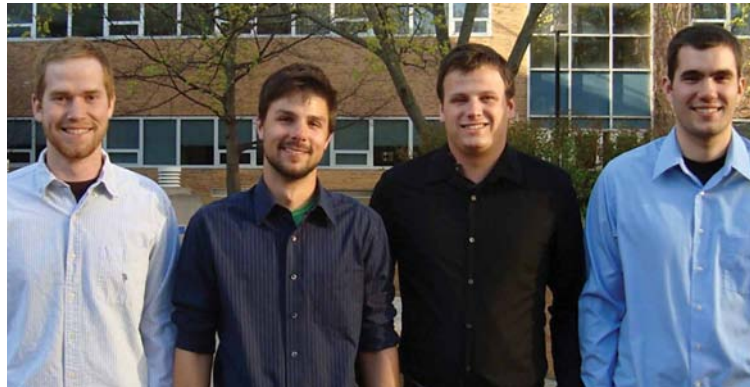

Team Members and Home Towns

Matthew Malek
Rochester Hills, MI

Michael Mehall
Kalamazoo, MI

Andrew Mozer
Rochester Hills, MI

Dan Pylar
Portage, MI

Project Sponsor

Macheo Children's
Centre
Thika, Kenya

Professional Advisor

Simon Wachieni
Operations Manager
Macheo

Faculty Advisor

Prof. Brian Thompson

Clean and accessible water is an essential resource that is unfortunately not widely available in all areas of the world. One such area is in Kenya, where people often struggle to find sources of clean water. For this reason, our Kenyan contact, Simon Wachieni working at the Macheo Children's Centre in Thika, informed us that a simple portable water pump for use in boreholes would be incredibly helpful.

Many important factors need to be taken into consideration for the design of a portable water pump. Furthermore the method of collecting water from distant water holes also necessitates transportation, which often requires women and children to carry gallons of water over great distances. Water's heavy. In order to combat these complications, a water pump was designed to ease the process of water acquisition, and eliminate the need for transportation when the water is being extracted from locally available boreholes. The pump's design specification is dictated by the local conditions, requiring a mechanical advantage to assist with the lifting of the water and taking into account that most users are women and children who are probably malnourished.

...The Macheo Portable Water Pump Student Design Team



A Bean Threshing Device for Guatemala



“The three largest bean producing countries in Central America, are Nicaragua, Honduras and Guatemala; the team visited Guatemala to investigate harvesting procedures”



Team Members and Home Towns

Zach Albright
Grand Haven, MI

Ben Ambrose
Canton, MI

Erika Crosby
Goodrich, MI

Khoa Nguyen
Grand Rapids, MI

Project Sponsor

Michigan State University

Professional Advisor

Dr. Luis Flores
Institute of International Agriculture

Faculty Advisor

Prof. Brian Thompson

In Central America, beans (black and red Phaseolus) are a major item in the daily diet. These beans are primarily grown by small plantation subsistence farmers and the three largest bean producing countries in the isthmus separating the Pacific Ocean from the Caribbean Sea are Nicaragua, Honduras and Guatemala. However despite the great regional importance of these crops, the small plantation farmers lack advanced methods of removing the beans from each pod, called threshing, and the situation is further exacerbated because in Central America there are generally two growing seasons each year and therefore two harvesting seasons.

In order to develop a deeper knowledge of current bean threshing practices, Dr Flores our professional advisor, organized a week-long field excursion to Guatemala. There, the team was able to formally interview a large number of subsistence farmers using a questionnaire; interact with horticultural professionals in a variety of locations in the nation; observe first-hand, farming practices associated with crops of different beans; and finally examine in detail the current harvesting methods employed for a variety of different beans.

A bean threshing device has been meticulously designed and prototyped to solve the post bean harvesting process for the poverty-stricken farmers of Central America. This device will decrease the amount of time required to thresh beans, minimize the amount of beans lost, and decrease the negative effects on the human body. The current process involves the gathering of dried bundles of whole bean plants onto a large tarpaulin where workers repeatedly strike the plants with large wooden sticks. The innovative threshing device decreases the amount of time required to thresh beans and therefore increases the efficiency of the post-harvest processing of beans. The threshing forces are delivered with a foot-pedaling system in order to take advantage of the strongest muscles in the human body, the quadriceps.

...The Guatemalan Bean Threshing Student Design Team



Fruit of Our Labor Mango Dehydration Project for Macheo Children's Centre

“Working with the Macheo Children's Centre in Kenya, our team helped reduce the current 50% mango waste during the harvest season and also the malnutrition in the local population”



Team Members and Home Towns

Marcus Cannon
Farmington Hills, MI

Haley Orr
Royal Oak, MI

Nick Schooley
Lansing, MI

Michael Trotter
Linden, MI

Project Sponsor

Macheo Children's
Centre
Thika, Kenya

Professional Advisor

Simon Wachieni
Operations Manager,
Macheo

Faculty Advisor

Prof. Brian Thompson

Project “Fruit of Our Labor’s” objective was to develop a method of post-harvest preservation of fresh mangoes. Working with the Macheo Children's Centre in Kenya, our group addressed malnutrition and reduced the current 50% mango waste during the harvest season.

Our team will take a mission trip to Kenya following the conclusion of the semester. By implementing this dehydrator design, the community will have access to nutrient-rich mangoes year-round in contrast to the current two-month harvest season. Furthermore, the extended availability of vitamins and minerals will be beneficial for childhood development and the reduction of malnourishment. The implementation of our drying stations could provide entrepreneurial livelihoods for families and communities throughout Kenya.

Team “Fruit of Our Labor” comprises four innovative and dedicated Michigan State engineers. Through the years on campus we have developed a global perspective of life on planet Earth and we have an earnest desire to apply our knowledge through humanitarian efforts.

...The Macheo “Fruit of Our Labor” Student Design Team



The A-maiz-ing Kenya Project for Macheo Children's Centre



“My dream is to help women and children in Africa have access to good nutrition and the critical information that will help them to be in charge of their lives & livelihoods and end the circle of poverty.”

Jane Mutatu,
East African Farmer
Zimbabwe



Team Members and Home Towns

Karsten Harns
Lansing, MI

Andrew Nuttall
Stephenson, MI

Jared St. Aubin
Rochester Hills, MI

Scott Shaw
Haslett, MI

Project Sponsor

Macheo Children's
Centre
Thika, Kenya

Professional Advisor

Simon Wachieni
Operations Manager
Macheo

Faculty Advisor

Prof. Brian Thompson



Small maize farmers in Kenya confront many challenges during the process of selling their crops at a reasonable profit and providing food for their families. Maize is an important cash crop, but subsistence farmers often receive less money from commercial mills during the glut experienced at harvest time than they could if self-processing were a feasible option. One of the greatest hurdles to self-processing is the removal of kernels from the ears of maize; this is currently a very time-consuming and labor intensive task.

The Macheo Children Centre in Thika, Kenya petitioned MSU students to help subsistence maize farmers, by developing a low-cost human-powered mechanical device to promote faster shelling processes, while still remaining within the budgets of farmers with limited incomes. This device is also intended to aid farmers in milling their harvests to produce maize flour. Currently, access to milling devices is limited and can be costly for most subsistence farmers. Indeed many farmers must stagger the milling of their harvest over the course of a season due to the costs associated with milling, and this delay often causes the growth of various molds and fungi due to improper storage conditions.

In addition, the need for further fuel sources in rural Kenya has led to the development of a process to transform waste residue from maize harvesting into combustible charcoal. This charcoal can be either used and burned by the farmer, or sold to provide an additional source of income.

...The Macheo “A-maiz-ing Kenya” Student Design Team



“Children are one third of our population and all of our future.”

Select Panel for the Promotion of Child Health, For the U.S. Congress, 1981



Team Members and Home Towns

Scott Hall
Howell, MI

Kyle Justus
Midland, MI

Kameron Kline
Clinton Township, MI

Michael O'Brien
Midland, MI

Project Sponsor

Michigan State
University

Professional Advisor

Prof. Maurice Bennink
Food Science &
Human Nutrition

Faculty Advisor

Prof. Brian Thompson

A Device for Creating Nutritious Food for Young Children in Sub-Saharan Africa



Proper nutrition for any human being is essential, but it carries increased importance for young children in the prime of their development. A phrase used in the nutrition community is “the first 1000 days”: the most critical time for a child to have proper nutrition is during the first 1000 days following conception. Malnutrition is rampant in Sub-Saharan Africa due in part to a legion of environmental, political, and socio-economic determinants. Left in the wake of these circumstances are generations of children with impaired cognitive and physical development, leading to further challenges with regards to development in this region of the world.

A bounty of nutritious food exists in Tanzania and other sub-Saharan countries, but the technology and infrastructure to provide families with food supplements for their young children is lacking. Indeed the time and energy it takes to cook and prepare a separate meal for their children is often so overwhelming that they choose not to, and instead feed their children a diet with low energy and nutrient density, because water can be up to five miles away, and there is the additional burden of harvesting enough wood for the fire to cook an additional meal. Developing a low-cost method to prepare and adequately cook nutritious meals for babies is critical to creating a culture where children are well nourished.

The focus of this project was to develop a device that mixed raw ingredients available to most Tanzanians (corn, sorghum, millet, and cowpeas, among others) into a homogeneous, nutritious paste and cook it in a short time to provide weaning children (typically between 6 months and 2 years of age) with essential micronutrients. At the end of the semester, the device will be introduced to the Tanzanian people when the team visits East Africa.

...The “Tanzanian Titans” Student Design Team



Cassava Flour Production in Kenya: Macheo Children's Centre



“The successful implementation of this device permits subsistence farmers to increase their annual income. It will also increase the state of Kenyan health and food quality, and it offers the empowerment of the women who work on these farms”

The Macheo Children's Centre was founded in 2005 in Thika, Kenya, with the goal of giving children in Kenya a better future. Some of the programs offered by Macheo provide quality education to children, and a variety of projects to generate income to lessen the financial dependence on sponsors and donors.

Cassava is a staple crop in Kenya that is used in a variety of dishes and this project involved the creation of a human-powered device for transforming cassava roots into flour. The main issue with cassava is that once it has been removed from the ground, it becomes inedible within three days if it is not consumed, or processed into a stable state. The most common process completed to increase the shelf life of the cassava root is to mill it into flour, which will be edible for about two years. When working with cassava there is a toxicity concern, because the skin of the root contains cyanide, and this must be completely removed before processing.

The device that has been developed works in two stages. In the first stage, the peeled cassava root is dried in the sunlight. Next, this dried cassava is placed into the device, where it is milled into flour. This flour can then either be used in cooking to create a variety of dishes or stored for future consumption.

...The Macheo Cassava Flour Student Design Team



Team Members and Home Towns

Jared Dorvinen
Houghton, MI

Adi Kosgi
East Lansing, MI

Kyle Schubel
Harrison Twp, MI

Brian White
Troy, MI

Project Sponsor

Macheo Children's
Centre
Thika, Kenya

Professional Advisor

Simon Wachieni
Operations Manager
Macheo

Faculty Advisor

Prof. Brian Thompson

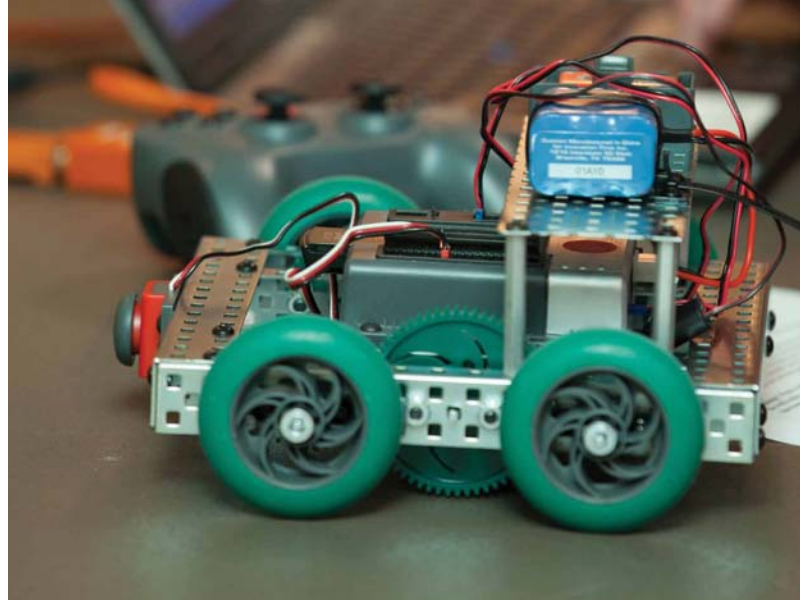

MICHIGAN STATE UNIVERSITY *Fall 2012*

Design Day

COLLEGE OF ENGINEERING

**Mark Your Calendars!!
It's time to save the date for
Fall 2012 Design Day!**

**Join us December 7, 2012, for another
energetic celebration showcasing talented
students in multiple engineering areas:**

Civil Engineering
Computer Science Engineering
Electrical and Computer Engineering
Mechanical Engineering

Check our new website often for
updates during the semester:
www.designday.egr.msu.edu

GO GREEN!!

MICHIGAN STATE
UNIVERSITY



Make a difference with GE.

Today, you've arrived at that point in the road where preparation meets opportunity, and it's time to decide where you will invest your future.

Why settle for anything other than the best leadership development programs and the widest number of career growth opportunities with one of the most admired companies in the world?

GE employs nearly 600 MSU alumni and is a proud sponsor of Design Day



GE Aviation



GE Healthcare



GE Appliances and Lighting



GE Transportation



imagination at work

To apply, visit ge.com/careers today!

MICHIGAN STATE --- UNIVERSITY



imagination at work

Directing Partner Sponsor of Design Day

**For information on
sponsoring Design Day
and design projects, contact**

Maureen Blazer-Adams
Director, Design Day
2244 Engineering Building
Michigan State University
East Lansing, Michigan 48824
(517) 432-6583 adamsme@msu.edu