

# Team 04 Ford

Ford Test Drive

Jeffrey Ignatius  
Ryan Wagoner  
Ronald Rodriguez  
Stephen Rice

# Corporate Sponsors

- Michael Volk
- Matthew Whitaker

# Project Overview (1 of 2)

- Place Sensors in Test Drive Vehicles
  - Form Mesh Network
  - Collect Data During Test Drives
- Mesh Network
  - Sensors Know Which Vehicles They Are In
  - Communicate With Neighbor Sensors
  - Allows 'Hopping' Data to Access Point
- Data Collection
  - Five Times per Second
  - 3D Accelerometer and Cabin Temperature

# Project Overview (2 of 2)

- Driver Profile
  - Driver Can Fill Out Forms Online Before Visit
  - Link in Database to Specific Test Drive
- Web Portal
  - Data Collected is Accessible to Ford Employees
  - Provides Charting and Graphing Capabilities
  - Customer Specific and Aggregate Data

# Customer Information

Ford Driver Profile - Mozilla Firefox

http://cse498t04s.cse.msu.edu/Team4Ford/Driver Profile Website/profileForm.php

ATS RS Link Test MSU Ignati.us Homepage

### LOGIN INFORMATION

E-mail Address:

Password:

Confirm Password:

### PERSONAL INFORMATION

First Name:

Middle Initial:

Last Name:

Address:

Address 2:

City:

State:

Zip Code:

Driver's License Number:

Birthday Month:  Day:  Year:

### CURRENT VEHICLE INFORMATION

Current Vehicle Make:

Current Vehicle Model:

Current Vehicle Year:

Done 1:47 Tor Disabled

# Dealership Website

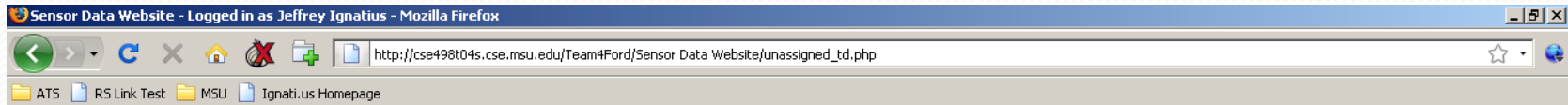

## Ford Motor Company

Welcome Jeffrey Ignatius

[Home](#)

Car Information

> [Add New Car](#)

> [View/Edit Cars](#)

Driver Profile

> [Add New Driver Profile](#)

> [View/Edit Driver Profiles](#)

Test Drive

> [Schedule Test Drive](#)

> [View Unassigned Test Drives](#)

> [View Test Drive Data](#)

Employees

> [Add Employee](#)

> [View/Edit Employees](#)

> [Change Password](#)

[Logout](#)

### List of Unassigned Test Drives

Sensor ID	Car	Driver	Test Drive		Average			Edit
			Start Time	End Time	Accel	Decel	Temp	
100	Volkswagen Passat	Ignatius, Jeffrey	Oct 16, 2008 10:00am					<a href="#">Edit</a>
133	Toyota Camry	Wagoner, Ryan D	Oct 22, 2008 4:30pm					<a href="#">Edit</a>
100	Volkswagen Passat	Smith, John M	Oct 26, 2008 4:00pm					<a href="#">Edit</a>

# Thread Overview

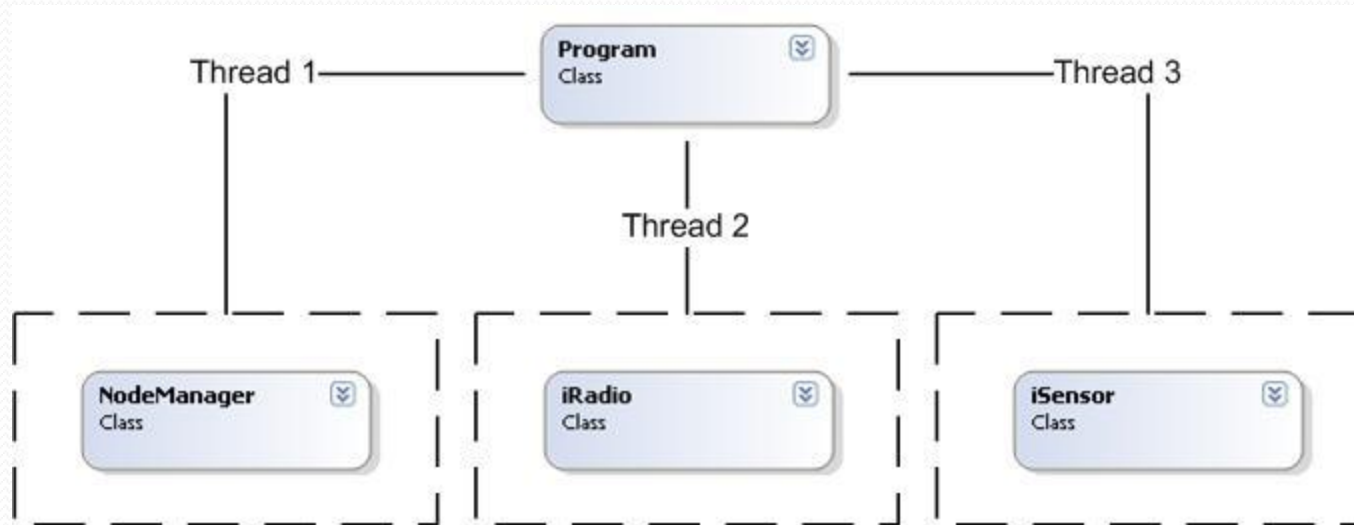

# Thread Management

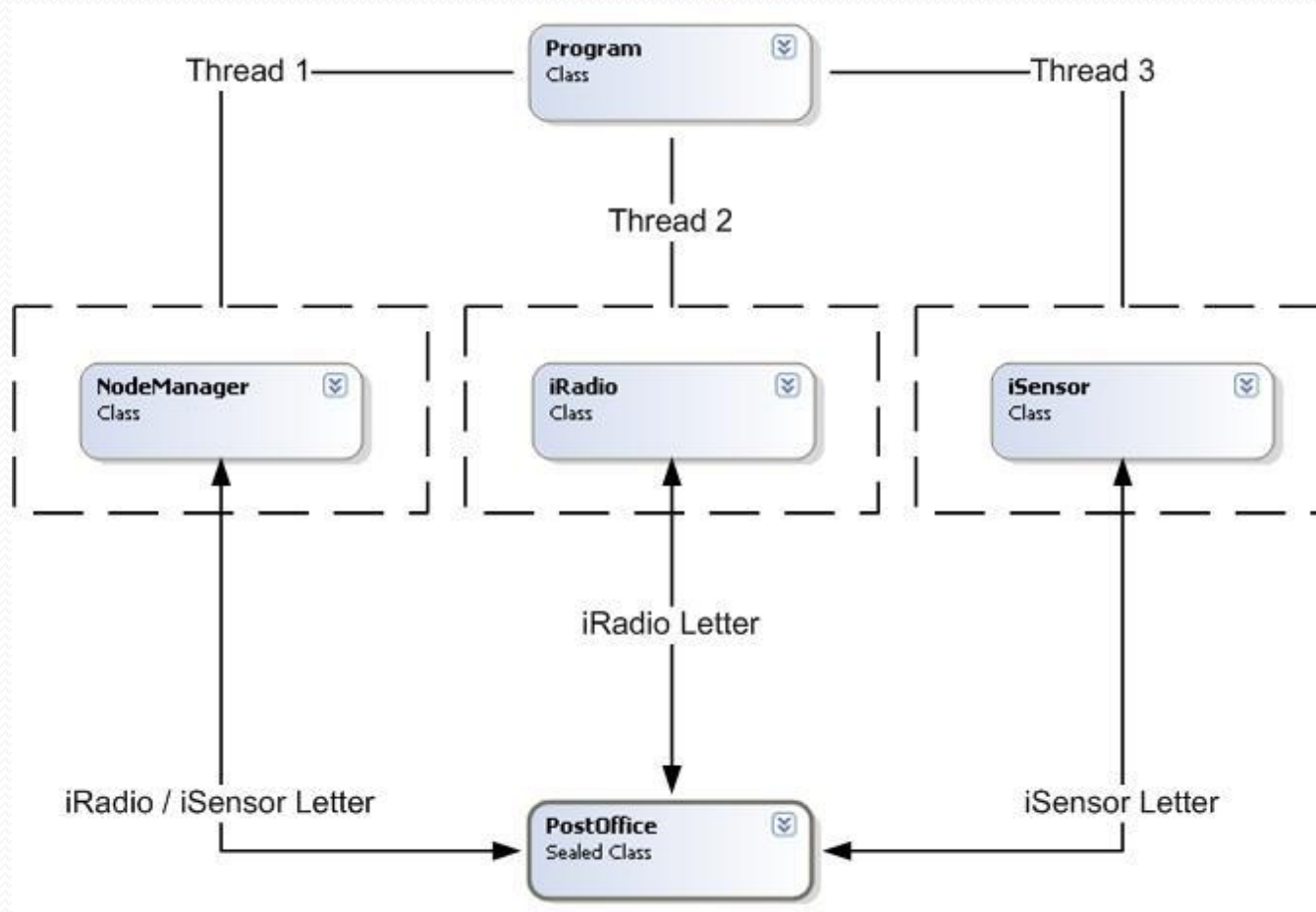



# Leaving the Network

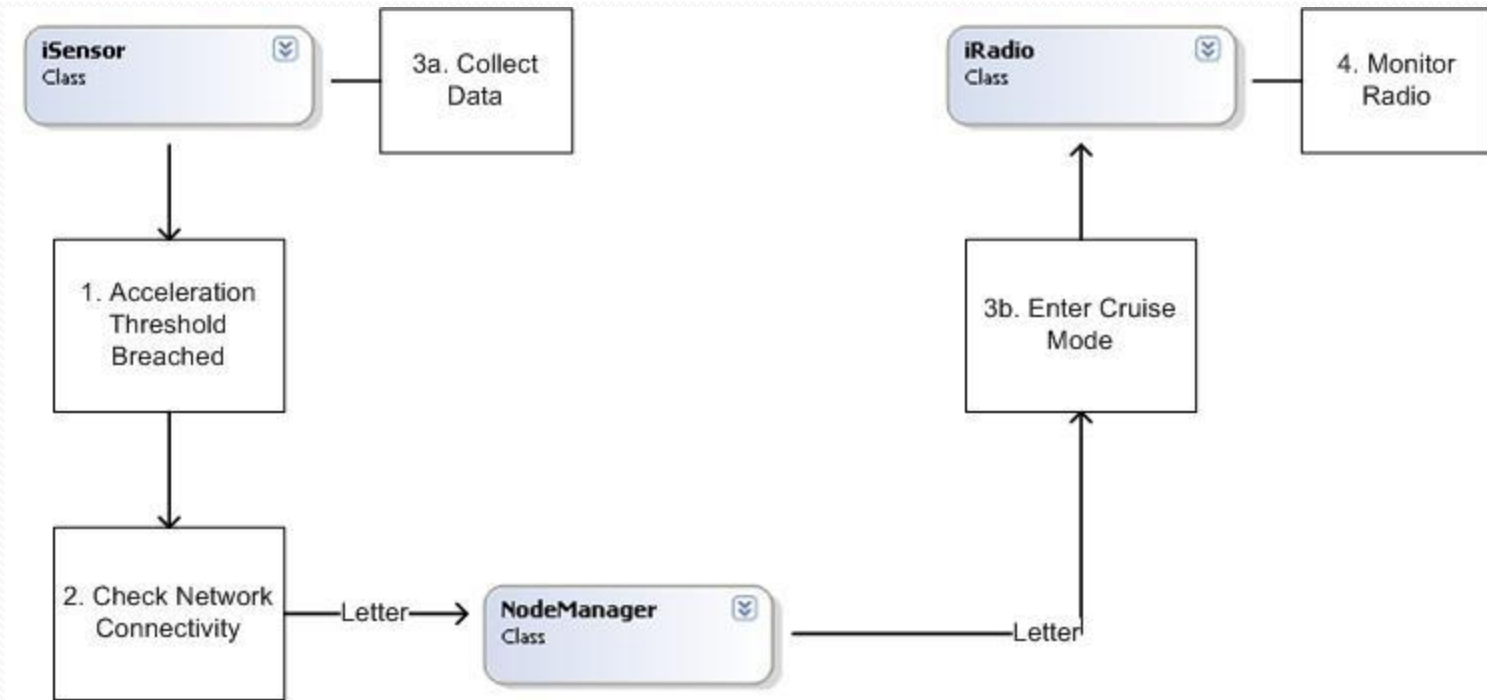

# Returning to the Network

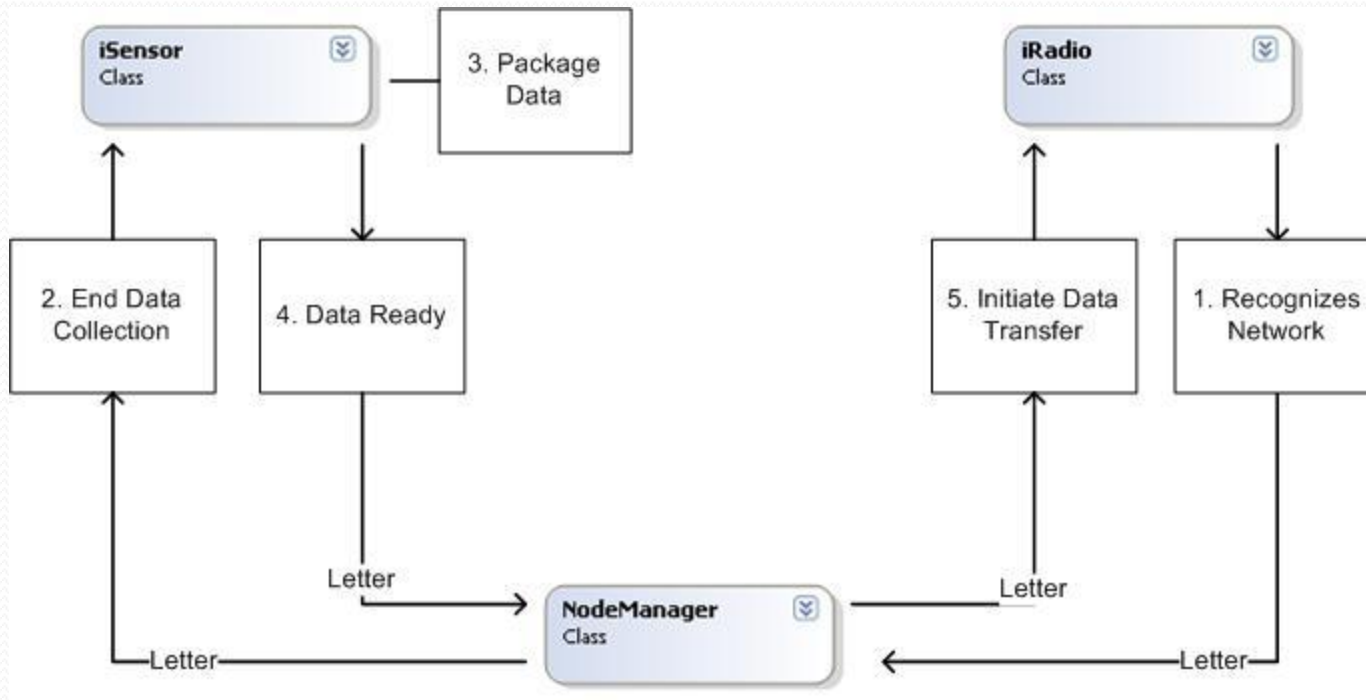

# Data Proliferation

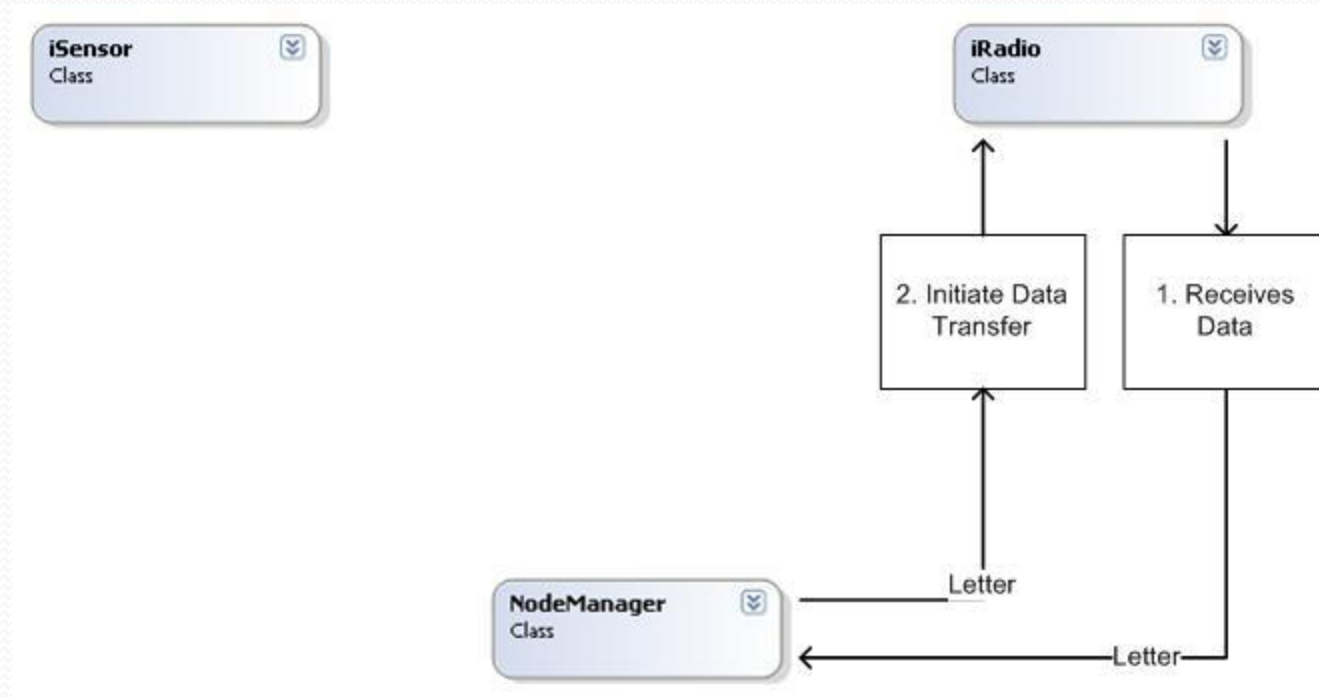

# Demonstration

- Data Collection Program
- LED Color Codes
  - Purple(blink): Sending Routing Packet
  - Blue(blink): Collecting Data
  - Yellow(solid): Out of network
  - White(solid): Attempting to Handshake
  - Red(blink): Sending Data Packet
  - Green(blink): Receiving Data Packet



# Questions?

## Thank You

Jeffrey Ignatius  
Ryan Wagoner  
Ronald Rodriguez  
Stephen Rice